

# 35kV 200kV BIL JSCS Series I Cold Shrink Sleeve

## Product Data Sheet

Richards Disconnectable Joints provide a robust, versatile option for splicing underground medium voltage cables. They can be used for straight or multiway splicing and can be disconnected for circuit isolation, grounding, expansion and more. Disconnectable Joints are molded from peroxide cured EPDM and are fully shielded and submersible.

The Richards 35kV Class 600/900A JSCS Series Cold Shrink Sleeve (P635JSCS/P935JSCS) is deployed on prepared cable legs to insulate and shield. Optional accessories for the Sleeve include Sleeve Restraints, Spiking Stem, and Joint Insulating Cap.

All 35kV JSCS kits are provided with interface clamps or sleeve restraints.



### Features

- Injection Molded Cold Shrink EPDM
- Fully-Shielded/Deadfront
- Range Taking
- Low-profile, space saving splicing solution
- Eliminates cable adapter, retaining ring, vent rod, and separate jacket seal
- Modular design
- Simplified Installation
- Short, easy-to-remove cores
- Designed, Molded, and Tested in the USA

### Basic Dimensions - Installed

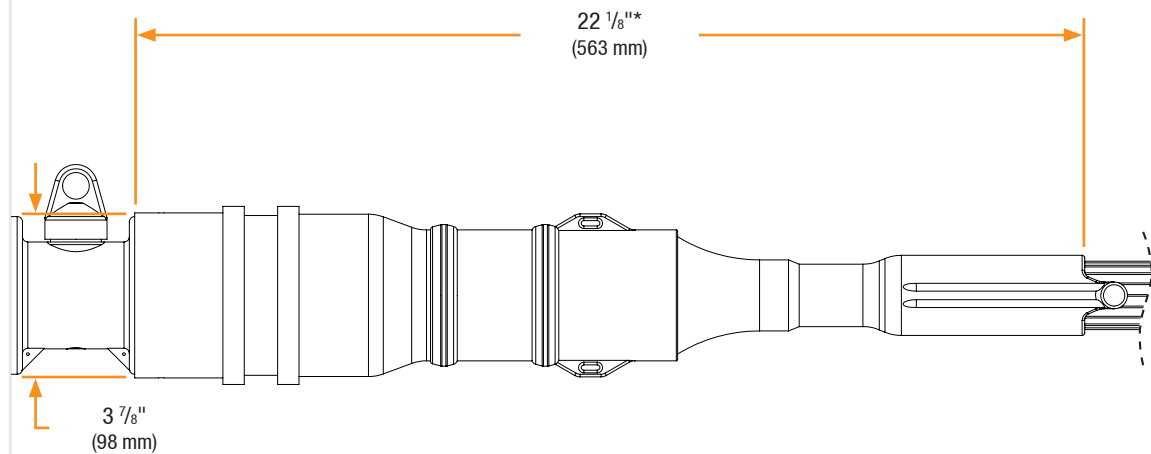

\* Approximate length - varies by cable size.

# 35kV 200kV BIL JSCS Series I Cold Shrink Sleeve

## Detail View

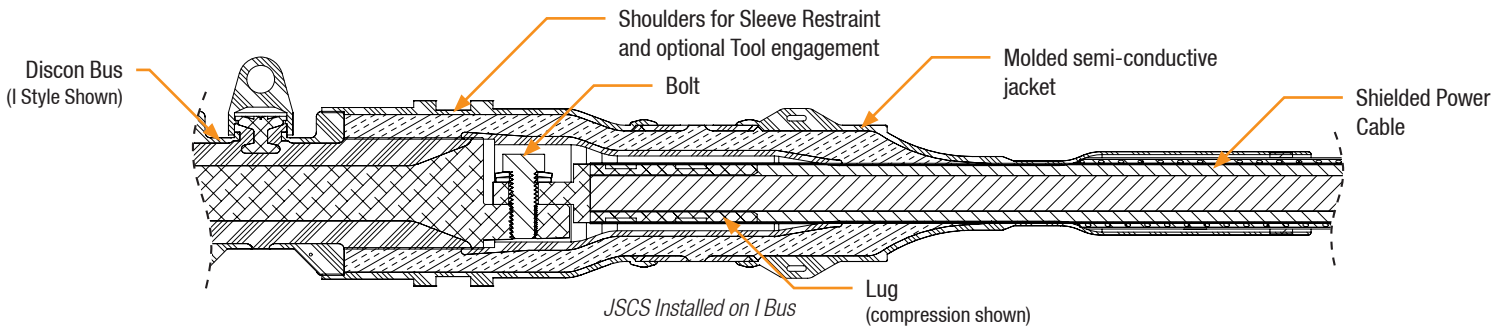
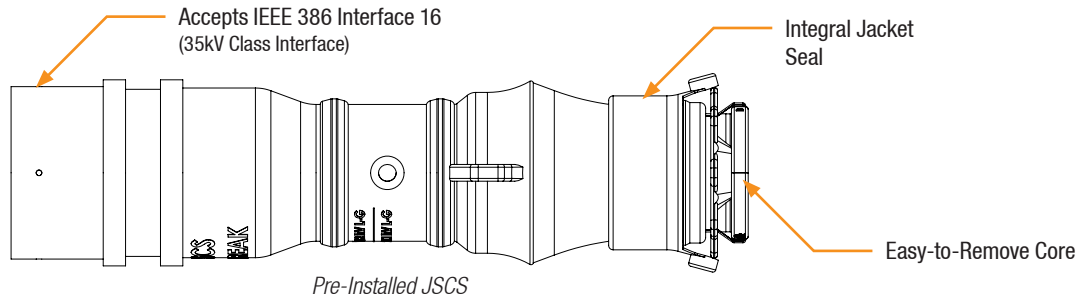

## Installation

35kV JSCS Series installation is covered by: **RP-II-93JSCS**

## Applicable Splice/Body Connector Sizes

O	P	Q
Minimum Insulation Diameter = 0.725"	Minimum Insulation Diameter = 0.990"	Minimum Insulation Diameter = 1.268"

## Production Testing

IEEE requires a Partial Discharge test and choice between AC withstand and Impulse.

Richards runs 3/3 tests on **all** Medium Voltage products governed by IEEE 386. <sup>®</sup>

### 100% Routine Electrical Test:

- Partial Discharge
- AC Withstand
- Impulse Withstand

<sup>®</sup> Exceeds IEEE 386 requirement

## Product Ratings

### Voltage Ratings

Maximum Voltage Rating – (phase to ground)	21.1kV
Corona Voltage Level – (partial discharge extinction voltage)	26kV
AC Withstand – (1 minute)	70kV <sup>®</sup>
Impulse-Withstand Voltage – (BIL)	200kV BIL <sup>®</sup>

### Continuous Current Ratings

Aluminum	600A
Copper	900A

### Short-Time Current Ratings

Aluminum	25kA, 10c. and 10kA, 3s.
Copper	40kA, 10c. and 10kA, 3s.

The 35kV JSCS Series is qualified to the following industry standards:

- IEEE Std 386: For Separable Insulated Connector Systems
- ANSI C119.4: For Electric Connectors
- IEEE Std 592: For Exposed Semiconducting Shields