

35kV Disconnectable "L" Bus

Product Data Sheet

The Richards Disconnectable Joint system is a multi-way medium voltage cable splicing system available through 35kV. Commonly found in higher load density underground systems, these Joints can be useful even for lighter loads due to their versatility and simplicity. Other methods involve complicated installations that are extremely difficult in congested underground distribution environments.

The Disconnectable Joint Bus is composed of a high-conductivity metallic bus contact overmolded with EPDM rubber. The various positions of the Bus allow for interconnection of medium voltage cables in an ultra-low-profile configuration. Accessories are also available for insulating, isolating, spiking and grounding..

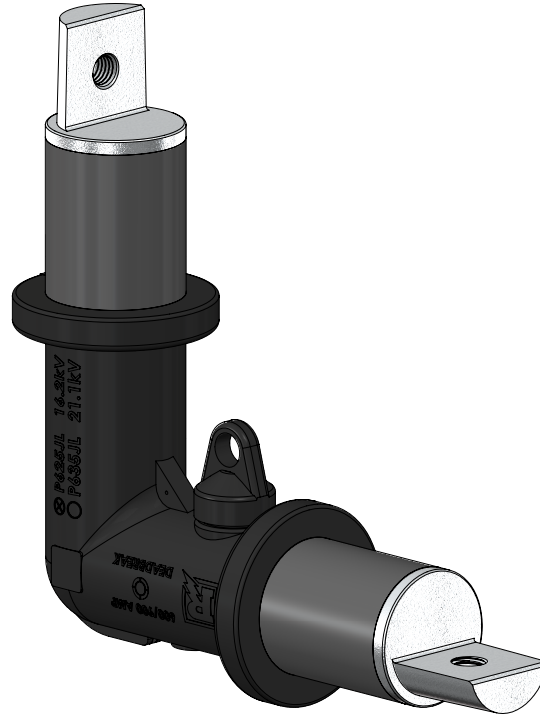

Features

- Injection Molded & Peroxide-Cured EPDM Rubber
- Designed, Tested, and Molded in the USA
- Fully-Shielded/Deadfront
- Submersible
- Dependable Multi-Way Splice
- Low-profile, space-saving splicing solution
- Modular design

Basic Dimensions

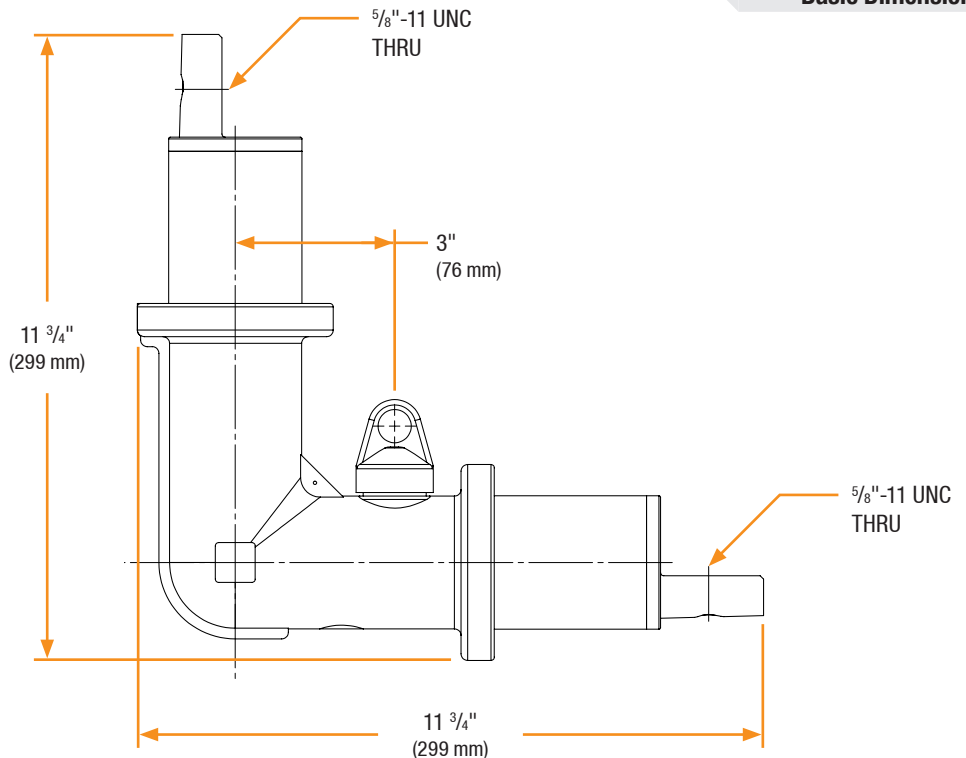

35kV Disconnectable "L" Bus

Related Products

P635JS

35kV Disconnectable Joint Sleeve

P635JSCS

35kV JSCS Series Cold Shrink Sleeve

93DSS0

15/25/28/35kV Spiking Stem Assembly

P635JIC

35kV Joint Insulating Cap

P6JGP

35kV Joint Grounding Plug

P6JPB

Barrier Bolt

P6AL-X

Aluminum Compression Lug

P9CU-X

Copper Compression Lug

P6ALR-X

Aluminum Range Taking Lug

P7ALCU-X

Copper-Top Compression Lug

Detail View

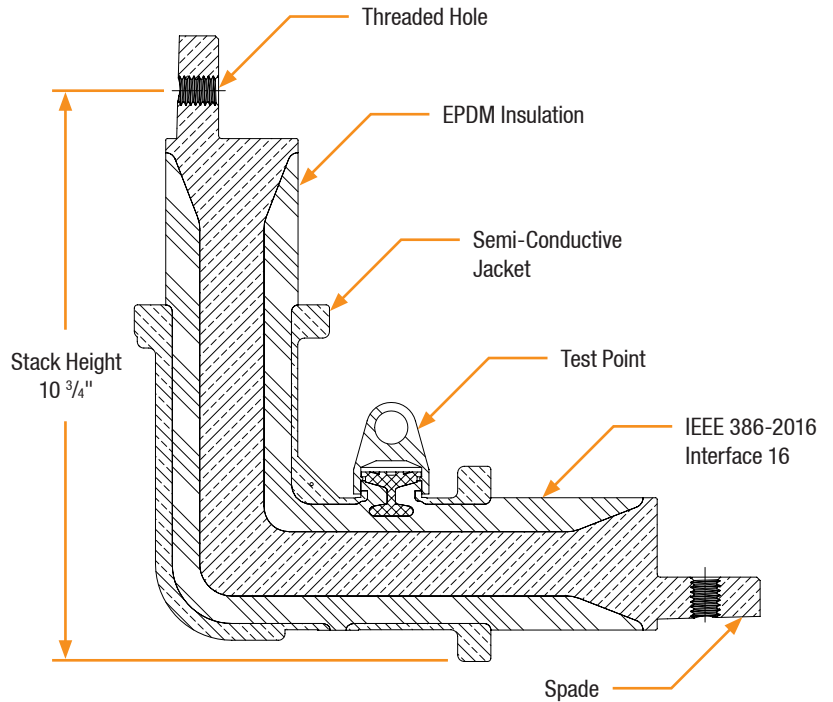

Production Testing

IEEE requires a Partial Discharge test and choice between AC withstand and Impulse.

Richards runs 3/3 tests on **all** Medium Voltage products governed by IEEE 386. [®]

100% Routine Electrical Test:

- Partial Discharge
- AC Withstand
- Impulse Withstand

Richards Disconnectable Buses are designed to allow for production testing at 200kV BIL. For more information contact the factory.

[®] Exceeds IEEE 386 requirement

Product Ratings

Voltage Ratings	
Maximum Voltage Rating – (phase to ground)	21.1kV
Corona Voltage Level – (partial discharge extinction voltage)	26kV
AC Withstand – (1 minute)	50kV
Impulse-Withstand Voltage – (BIL)	162kV BIL [®]

Continuous Current Ratings	
Aluminum	600A
Copper	900A

Short-Time Current Ratings	
Aluminum	40kA, 10c. and 10kA, 3s. [®]
Copper	40kA, 10c. and 10kA, 3s.

The 35kV Disconnectable "L" Bus is qualified to the following industry standards:

- IEEE Std 386: For Separable Insulated Connector Systems
- ANSI C119.4: For Electric Connectors
- IEEE Std 592: For Exposed Semiconducting Shields
- IEEE Std 404: For Cable Joints