

25kV R-800

Product Data Sheet

The R-800 is an innovative product that combines a Deadbreak Elbow and 200A Loadbreak tap. The integration of multiple components into a single preassembled/pre-tested body increases reliability and simplifies installation.

The R-800 is equipped with a stainless steel Fastener, a specialized internal component that is engaged by assembly tool to torque the assembly of R-800, Lug and mating component (i.e apparatus bushing). These fasteners come in several types designed to provide configurations that meet every application.



Features

- Combines 200A Loadbreak tap and Deadbreak Elbow
- Available in multiple configurations to meet every application
- Includes installation tool that guarantees proper torque*
- Reduces inventory and installation costs

* Applies to R-800's with 3/8" fasteners only.

Basic Dimensions

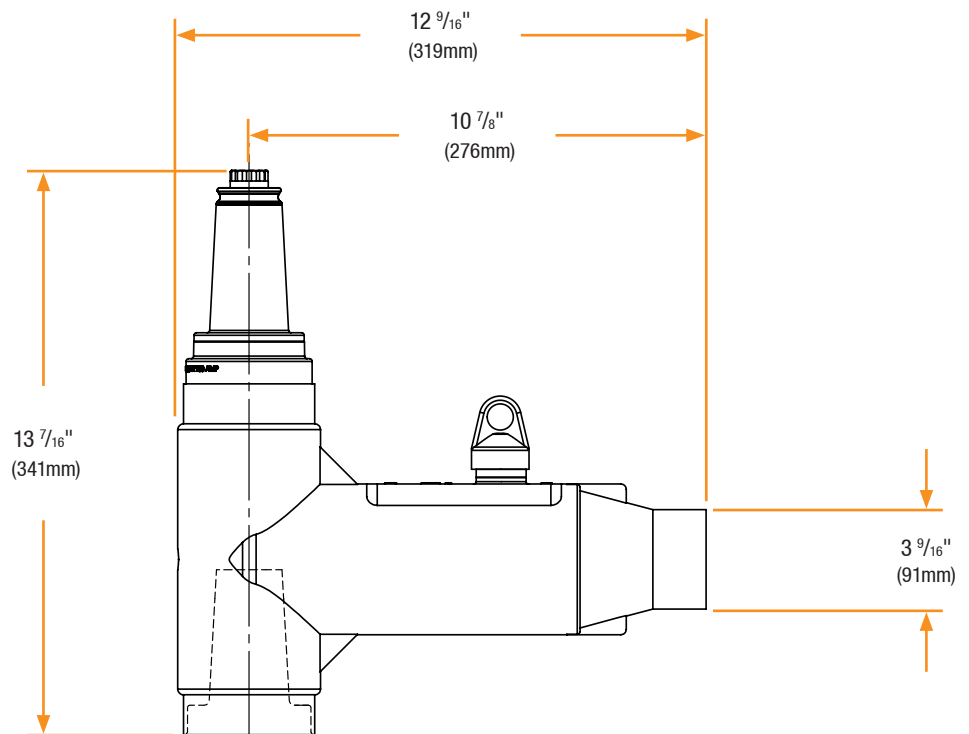

25kV R-800

Product Ratings

Voltage Ratings	
Maximum Voltage Rating – (phase to ground)	15.2kV
Corona Voltage Level – (partial discharge extinction voltage)	21kV [®]
AC Withstand – (1 minute)	40kV
Impulse-Withstand Voltage – (BIL)	125kV BIL

Current Ratings (Deadbreak Side)	
Continuous – (Aluminum)	600A
Continuous – (Copper)	900A
Short-Time Current – (Aluminum)	25kA, 10c. and 10kA, 3s.
Short-Time Current – (Copper)	40kA, 10c. and 10kA, 3s.

Current Ratings (Loadbreak Side)	
Continuous	200A
Short-Time Current	10kA, 10c. and 3.5kA, 3s.

The 25kV Class R-800 is qualified to the following industry standards:

- IEEE Std 386: For Separable Insulated Connector Systems
- ANSI C119.4: For Electric Connectors
- IEEE Std 592: For Exposed Semiconducting Shields

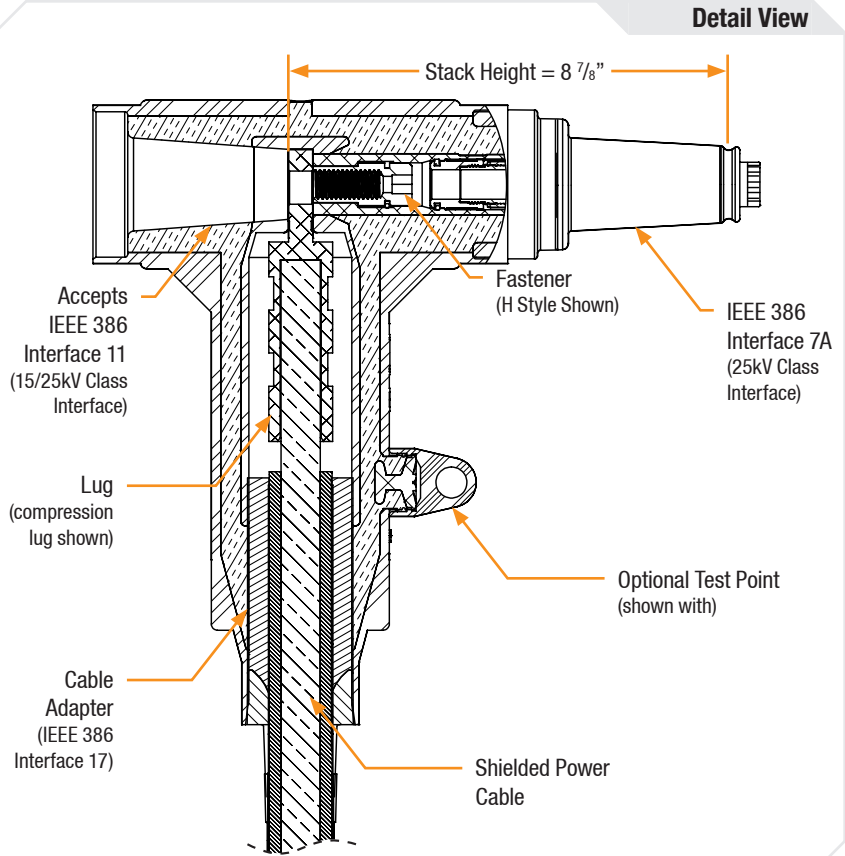

Production Testing

IEEE requires a Partial Discharge test and choice between AC withstand and Impulse.

Richards runs 3/3 tests on **all** Medium Voltage products governed by IEEE 386. [®]

100% Routine Electrical Test:

- Partial Discharge
- AC Withstand
- Impulse Withstand

[®] Exceeds IEEE 386 requirement

R-800 Fastener Styles

Currently Using:	Upgrade to R-800 Type:	Installation Torque	Tool Size	Lug	Stick Operable*	Male or Female**	One-Piece Design
Elbow Tap Plug (ETP) or Bushing Insert + Reducing Tap Well	H	55 ft-lbs	3/8"	Regular	No	Female	Yes
T-OP II	G	20 ft-lbs	5/16"	15/16" Hole	Yes		
Loadbreak Reducing Tap Plug (L RTP)	M	55 ft-lbs	3/8"	Regular		Male	

* Stick operability is defined here as the ability to remove the R-800 from the bushing without the assembly of R-800/Cable/Lug being separated.

** Female R-800's come with a loose threaded stud. Male R-800's have the threaded stud built into the fastener.