

SSC Series

Cold Shrink Splice
2022 PRODUCT GUIDE



15/25kV
Class

35kV
Class

SSC Series

INTRODUCTION & PRODUCT RATINGS

Built for durability in the toughest environments

The SSC Series from Richards Manufacturing is a cold shrink splicing system for use on medium voltage power cables through 35kV. Equipped with numerous advantages and features, the SSC Series is an innovative, high-performance splicing solution.

The Splice is a hybrid design, incorporating the best features of cold shrink and push-on technologies. For example, our Splice provides the benefits of cold shrink—integral jacket seals, range taking capabilities—and yet it also can be furnished with a capacitive test point.

Molded entirely from Richards' cold shrink EPDM materials, the Splice is built for durability in the toughest environments. The SSC Series is fully qualified to IEEE Std 404™; the product ratings are listed below for your reference.

- **Integrated Solution:** The SSC is range-taking and includes an integral jacket seal, providing a complete solution in a simple package. Three separate components have been elegantly combined into a single design.
- **100% EPDM:** Richards Cold Shrink Products are molded from 100% EPDM, a proven material in underground electrical applications for decades. This proprietary formulation of Cold Shrink EPDM is produced in-house. To achieve maximum durability in underground environments, the SSC features a fully-integrated EPDM jacket that provides outstanding mechanical impact/tear resistance.
- **Easy Installation:** We've optimized our design to minimize installation time, complexity, and overall cost.
- **Designed, Molded & Tested in the USA:** Our team is intimately involved in everything from material development, product and mold design, and production. This allows us to control every aspect of the design, down to the smallest detail.

IEEE 404 - Industry Minimum Requirements

For your reference, IEEE ratings are provided below. Many of our products exceed these ratings. For product-specific information, see appropriate Product Data Sheet or contact the factory.

Voltage Ratings			
Voltage Class, Phase-to-Phase	15kV	25kV	35kV
Maximum Operating Voltage – (phase-to-ground)	8.7kV	14.4kV	20.2kV
Corona Voltage Level – (partial discharge extinction voltage)	13kV	22kV	30kV
AC Withstand – (1 minute)	35kV	52kV	69kV
Impulse-Withstand Voltage – (BIL)	110kV	150kV	200kV

Current Ratings	
Continuous Current	Cable Rated
Short-Time Current*	

* Maximum 40kA for 10 cycles per IEEE Std 404™

OUR TESTING EXCEEDS INDUSTRY REQUIREMENTS. IEEE REQUIRES PARTIAL DISCHARGE PLUS A CHOICE OF AC OR IMPULSE WITHSTAND. RICHARDS RUNS ALL THREE TO ENSURE THE HIGHEST QUALITY.

Designed and tested per the following industry standards:

- IEEE Std. 404: For Extruded and Laminated Dielectric Shielded Cable Joints
- IEEE Std. 592: For Semiconducting Shields

SSC Series

DESIGN & FEATURES



Neutral Options



Connectors

Capacitive Test Point



EPDM Construction

Easy-to-Remove Core

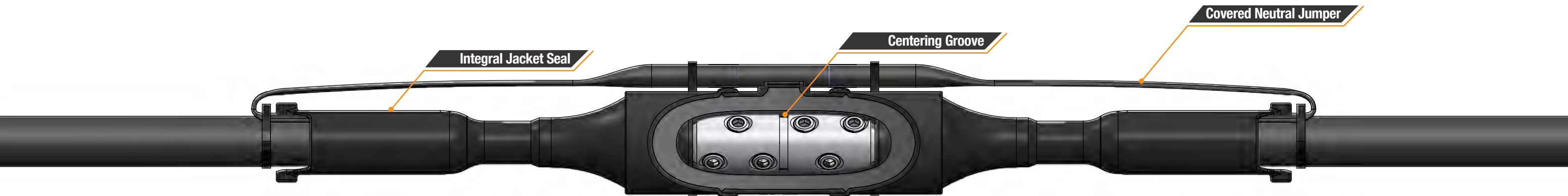

Integral Jacket Seal

Centering Groove

Covered Neutral Jumper

1. Connectors

Our shear bolts are engineered to break below the surface of the connector regardless of cable cross section. This eliminates the need for filing down protruding sharp edges, which can introduce contamination and cause failure. Our Connector and Cold Shrink Splice were carefully engineered and tested to ensure they work together as a proven, solid system—no more guessing about connector/housing compatibility.

2. EPDM Construction

The SSC is molded entirely from EPDM, a proven material in underground electrical applications. Our oil-resistant cold shrink material was formulated in-house, and is produced by our rubber manufacturing division. The durable, bonded semi-conductive jacket of the splice provides outstanding mechanical impact/tear resistance. The splice body is fully-shielded and passes industry qualification testing without any mesh or sock.

3. Integral Jacket Seal

The SSC is equipped with integral jacket seals, making sealing the metallic shield and outer jacket incredibly easy. The jacket seals are deployed over supplied sealing mastic, forming a dependable barrier against water ingress.

4. Centering Groove

A common concern when installing a cold shrink splice is ensuring the splice is properly seated. Improper positioning of a splice can result in electrical failure. The centering groove on our splice prevents this issue by ensuring the splice body is properly seated. As it is pushed from the parked position to the center of the connector, the splice will reach a positive stop when correctly seated. The splice will stay in the center while the cable prep and removal of the cores is completed.

5. Capacitive Test Point

The center of the splice is unexpanded, allowing for an optional capacitive test point. In fact, the SSC Series is the only cold shrink splicing solution on the market equipped with this feature.

6. Easy-to-Remove Core

Hold-out cores that rely on grease or a ribbon/spiral design can be unreliable and messy. Spiral holdouts can be difficult to remove and may prematurely collapse. Richards product development engineers created a compact core design that is easy to eject, and performs consistently across a variety of installation environments. Once ejected, the Core separates into halves which can be recycled.

7. Neutral Options

Bare Neutral Jumper (BNJ): Neutral connection using folded-back cable neutral wires/straps connected across splice.

Covered Neutral Jumper (CNJ): Neutral connection across splice utilizing Richards innovative Covered Neutral Jumper (CNJ). Features integral constant force spring and pull loop for ease of installation and improved ergonomics.

SSC Series

ORDERING INFORMATION

Sample Part Number

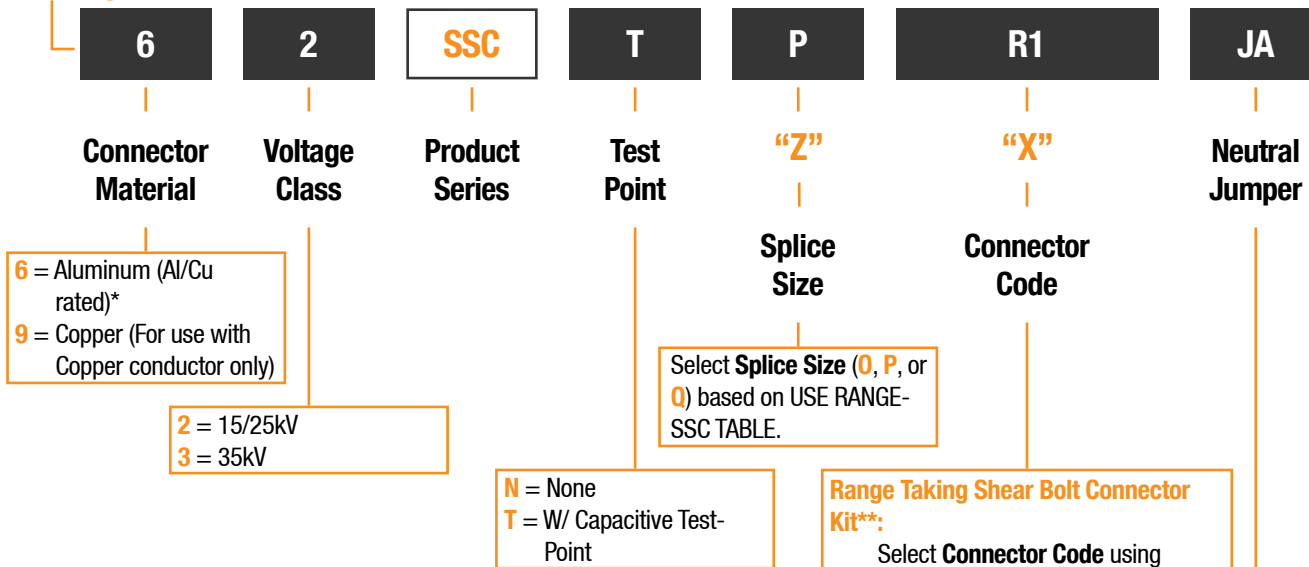

Table X - Size-Specific Connector Selection

Conductor Size	Strd/Compr	Cmpt/Sol
	"X"	"X"
#2	7	6
#1	8	7
1/0 AWG	9	8
2/0 AWG	10	9
3/0 AWG	11	10
4/0 AWG	12	11
250 kcmil	13	12
300 kcmil	14	13
350 kcmil	15	14
400 kcmil	16	15
450 kcmil	17	16
500 kcmil	18	17
550 kcmil	20	18
600 kcmil	20	18
650 kcmil	211 [†]	20
700 kcmil	22	20
750 kcmil	23	211 [†]
800 kcmil	24	22
900 kcmil	26	23
1000 kcmil	28	26
1100 kcmil	285	contact factory

[†] For copper P9CU Series Lugs, use code 21 instead.

* Aluminum Size-Specific Shear Bolt Connectors are only available at or above 350 kcmil.

** Range Taking Shear Bolt Connectors are only available in aluminum (Al/Cu rated).

Sample Part Number is a 15/25kV SSC Kit. Kit includes Size "P" Splice (with Test Point), Range Taking Aluminum Shear Bolt Connector (1/0 AWG - 500 kcmil Cmpt), and 1/0 AWG Covered Neutral Jumper.

SSC Series

SIZING OPTIONS

The following product sizing information is based on AEIC/ICEA dimensional ranges. The true range of the SSC Series on a particular cable construction may vary. To confirm sizing on non-standard cables, or to check sizing on cables that fall just outside our min or max, contact the factory.

Table XRA-SSC - Range Taking Connector Selection†

Connector Code "X"	Splice Size	Conductor Size	
		Minimum	Maximum
R1	O	#3 AWG	300 kcmil
R2		1/0 AWG	450 kcmil
R1	P	1/0 AWG	450 kcmil
R2		350 kcmil	750 kcmil
R1	Q	350 kcmil	750 kcmil
R2		600 kcmil	1250 kcmil

† Range Taking Shear Bolt Connectors are only available in aluminum (Al/Cu rated).

Use Range-SSC Table

Splice Size	Voltage Class	Conductor Size	
		Minimum	Maximum
O Minimum Insulation Diameter = 0.725"	15kV (175 mil)	1/0 AWG*	350 kcmil
	15kV (220 mil)	#2 AWG**	250 kcmil
	25kV (260 mil)	#4 AWG	4/0 AWG
P Minimum Insulation Diameter = 0.990"	15kV (175/220 mil)	350 kcmil***	600 kcmil
	25kV (260 mil)	4/0 AWG	500 kcmil
	35kV (345 mil)	1/0 AWG	250 kcmil
Q Minimum Insulation Diameter = 1.268"	15kV (175 mil)	750 kcmil	1100 kcmil
	15kV (220 mil)	600 kcmil	
	25kV (260 mil)	500 kcmil****	750 kcmil
	35kV (345 mil)	350 kcmil	

* May not fit some 1/0 AWG compressed/compact 100% (175mil) insulated power cables. Check minimum insulation diameter to confirm.

** May not fit some #2 AWG compact 133% (220 mil) insulated power cables. Check minimum insulation diameter to confirm.

*** May not fit some 350 kcmil compact 100% (175 mil) insulated power cables. Check minimum insulation diameter to confirm.

**** May not fit some 500 kcmil compact insulated power cables. Check minimum insulation diameter to confirm.

