

517 Lyons Ave, Irvington, NJ 07111  
Phone: 973-371-1771  
Fax: 973-371-4304  
www.richards-mfg.com

# Installation Instructions

## Deadbreak Elbow

### Applicable Current Ratings

600A (Aluminum) | 900A (Copper)

### Applicable Voltage Classes

35kV

### Applicable Catalog Prefix

#### 35kV Class

63LCN- | 73LCN- | 93LCN-  
63LCT- | 73LCT- | 93LCT-

### For Use With the Following Cable Types

Jacketed Concentric Neutral (JCN)  
Longitudinally Corrugated Neutral (LC)  
Tape Shield Neutral

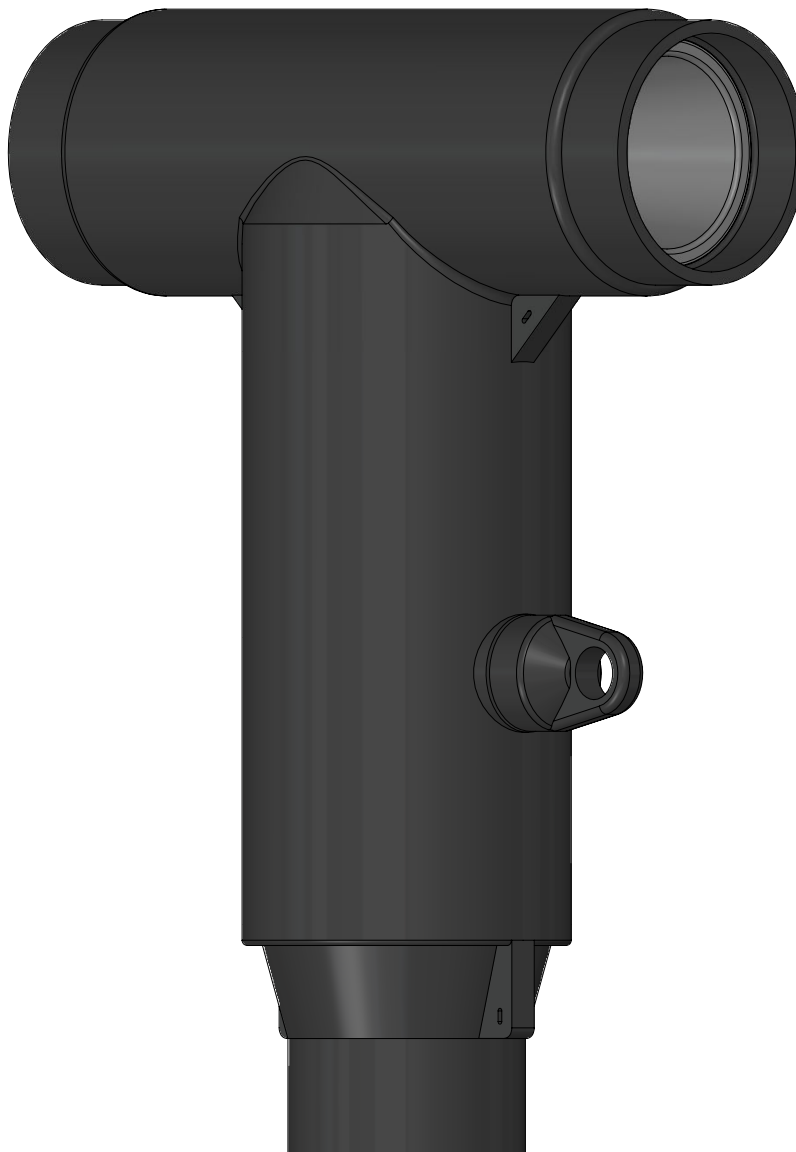



**WARNING**

- System must be de-energized during installation or future operation of this product or its components.
- Do not touch or move energized connectors or components by hand.
- Excess distortion of the assembled connector may result in its failure.
- Failure to follow these instructions will result in damage to the connector and serious or fatal injury.
- This product should only be installed and/or operated by trained personnel in accordance with normal and safe work procedures.
- Variations in equipment or configuration or work procedures may not be covered in these instructions.
- Please contact Richards Manufacturing for any additional questions.

**KIT CONTENTS**

Standard kits may include the following. Custom kits may vary.  
Check package contents to be sure they are complete, undamaged, and properly sized for the application.

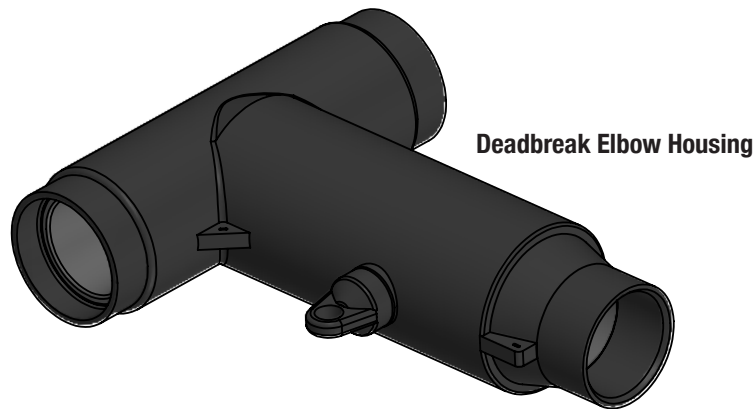

**Deadbreak Elbow Housing**

**Insulating Plug & Cap**

P635HIP  
P935HIP

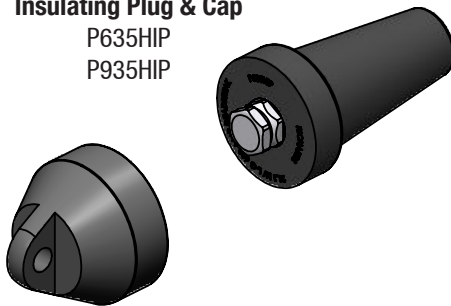

**Cable Adapter & Assembly Aid**  
P635CA-W

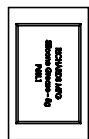
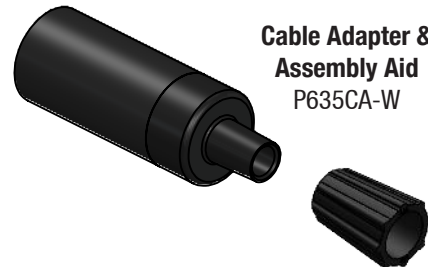

**Silicone Lubricant**  
P6SL1



**Stud**  
P635HIP-STUD  
P935HIP-STUD



**Range Taking Shear Bolt Lug**  
P6ALR-X

OR

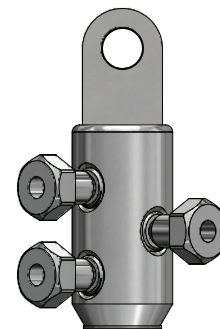

**Size Specific Shear Bolt Lug**  
P6ALS-X

OR

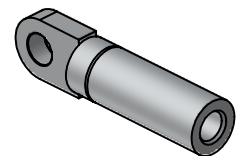

**Compression Lug**  
P6AL-X  
P7ALCU-X  
P9CU-X

**TIP:** Use To-Scale Cable Cutback Template as aid to prepare cable.

**NOTE:** Certain items used, such as PVC tape, may not be included.

**1**

**Positioning Cable**

- A. Straighten and train cable end. Cable should be free to move approximately 2" in either direction.
- B. Cut cable to dimensions shown.
- C. Clean cable jacket approximately 24" from end of cable.

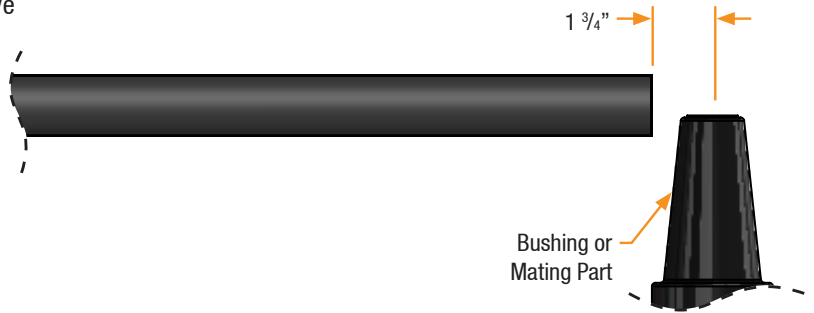

**2**

**Exposing Cable Shielding**

- A. Remove cable jacket to dimensions shown.
- B. Abrade area as shown.

**NOTE:** Cable Shielding may be wires, straps, metallic tape, or LC tape. (Wires shown as example)

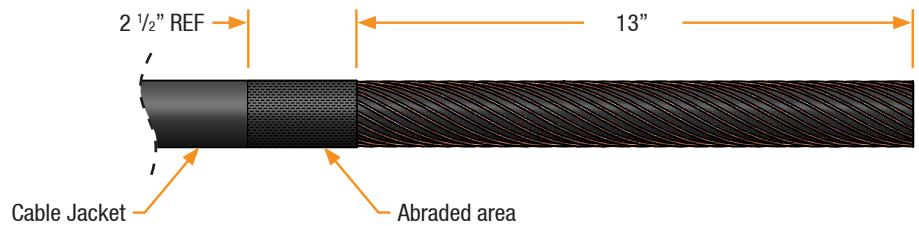

**3**

**Applying Jacket Mastic**

- A. Apply jacket mastic at position shown by stretching and wrapping with light tension fully around outer jacket.

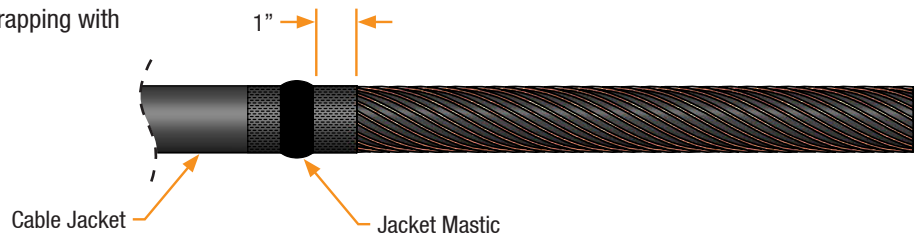

**4**

**Exposing Cable Semi-Conductive Shield**

**For Strap/Wire Shielded Cable**

- A. Fold back strap/wire shields and press firmly into jacket mastic.
- B. Secure strap/wire shields to cable with PVC tape as shown.

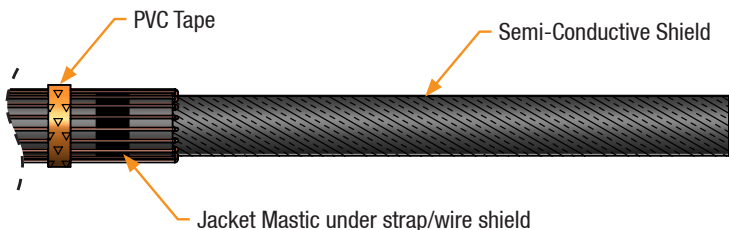

**For Metallic Tape/LC Shielded Cable**

- A. Wrap PVC tape at dimension shown to secure metallic shield.
- B. Remove metallic shield up to PVC tape.

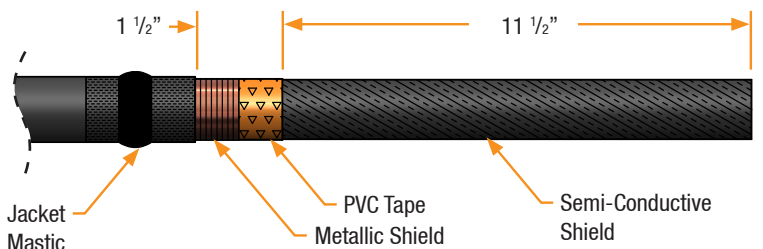

**5**

**Exposing Cable Insulation**

**For Strap/Wire Shielded Cable**

- A. Remove semi-conductive shield to dimensions shown.
- B. Place PVC tape marker at dimension shown.



**WARNING: Do not nick or cut the cable insulation.**

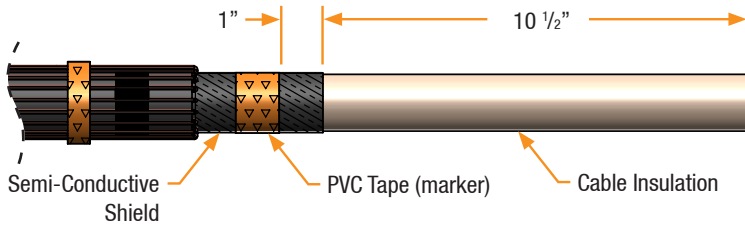

**For Metallic Tape/LC Shielded Cable**

- A. Remove semi-conductive shield to dimensions shown.
- B. Check that tape from previous step is 1" from the edge of the semi-conductive shield as it will serve as a marker.



**WARNING: Do not nick or cut the cable insulation.**

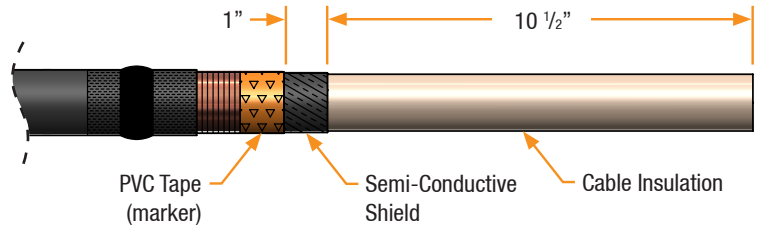

**6**

**Preparing Metallic Shield**

**For Strap/Wire Shielded Cable**

Proceed to next step

**For Metallic Tape/LC Shielded**

- A. Position copper braid so that solder block rests on the jacket mastic.
- B. Wrap copper braid around metallic shield as shown.
- C. Wrap constant force spring over wrapped portion of copper braid.
- D. Wrap 2 layers of PVC tape over constant force spring.
- E. Press solder block into jacket mastic.
- F. Secure braid to cable with PVC Tape.

**CHECK:** Confirm that solder block is aligned with jacket mastic.

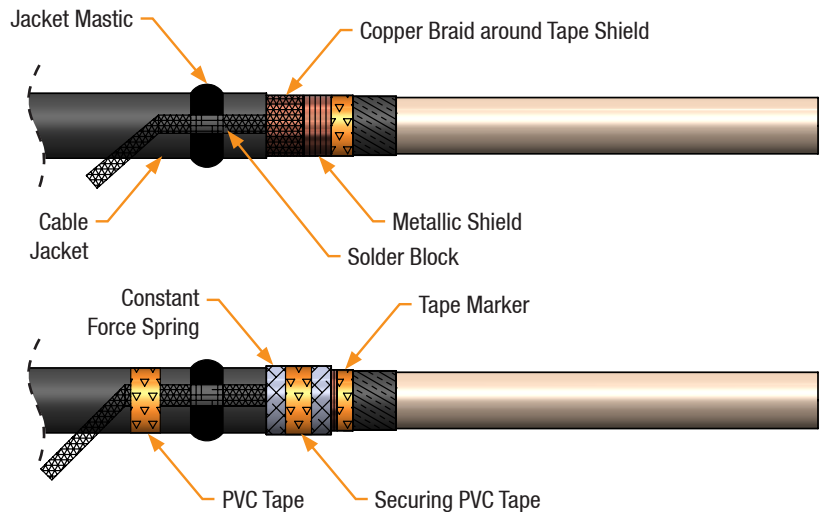

**7**

**Exposing Conductor**

- A. Remove cable insulation. Refer to instructions provided with lug for insulation cutback dimension. Cutback dimension should not exceed 4 3/8".



**WARNING: Do not nick or cut the conductor strands.**

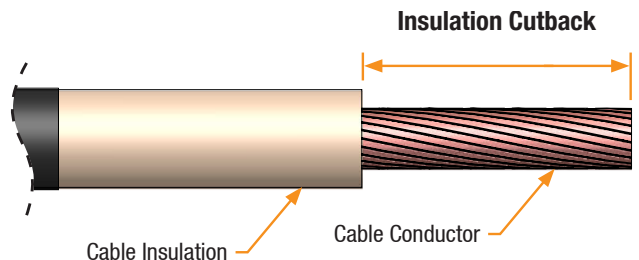

**NOTE:** Confirm all dimensions with To-Scale Cable Cutback Template before proceeding.

8

**Parking Jacket Seal Tube**

A. Slide jacket seal tube onto cable as shown. If using a cold shrink tube, orient pull tab facing away from cable end.

**For Strap/Wire Shielded Cable**

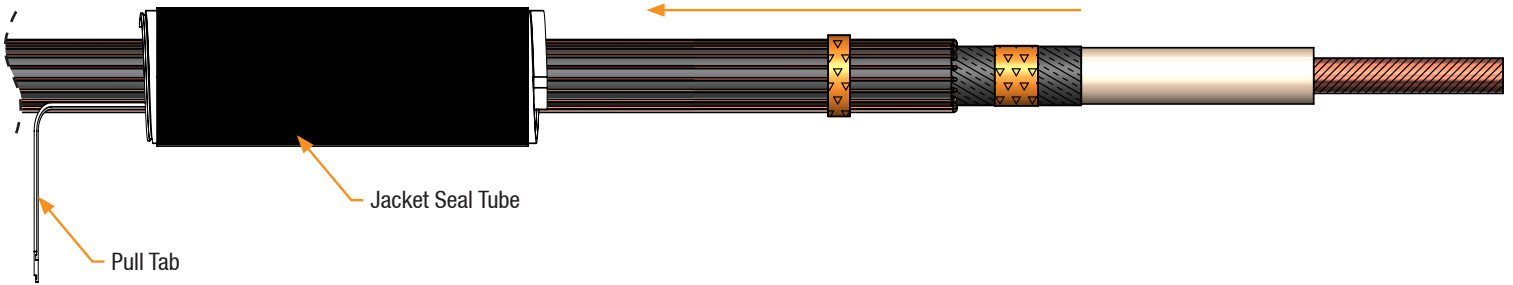

**For Metallic Tape/LC Shielded Cable**

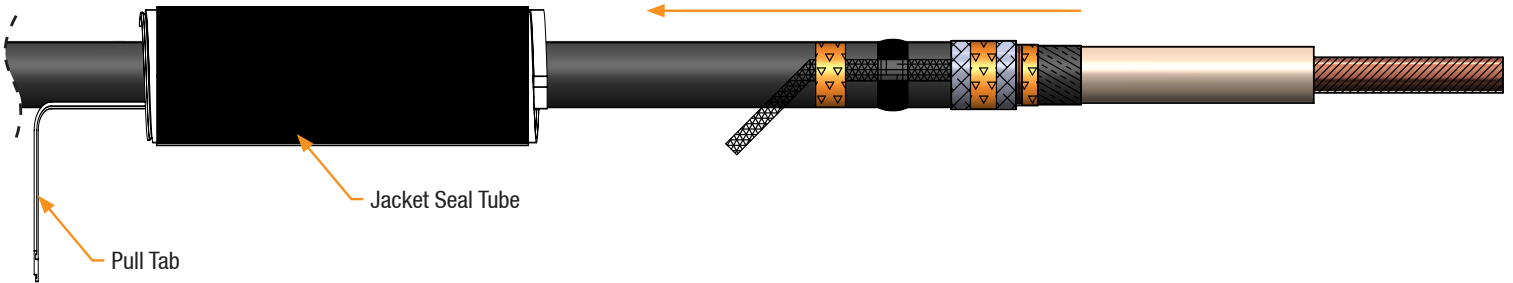

9

**Installing Cable Adapter**

- A. Slide cable adapter assembly aid up to insulation.
- B. Clean insulation with approved cleaning wipes by wiping in direction of semi-conductive shield.
- C. Apply silicone lubricant to cable insulation, cable adapter assembly aid, and inside of cable adapter as shown.
- D. Slide cable adapter onto cable until the cable adapter sits flush with the leading edge of the tape marker as shown.

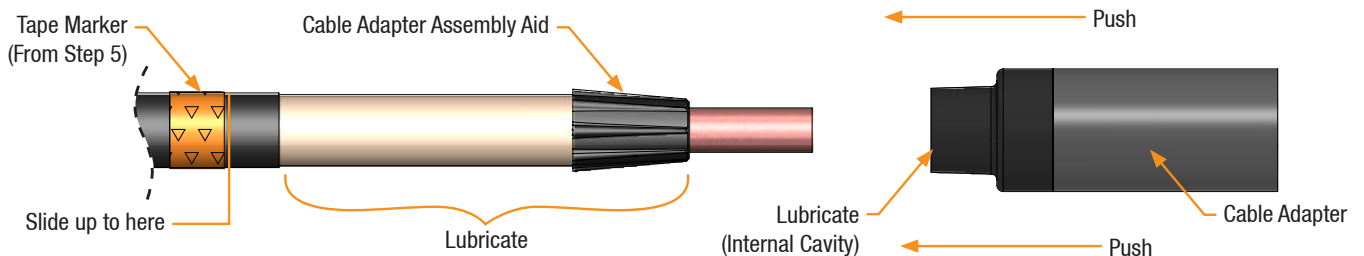

- E. Remove cable adapter assembly aid.
- F. Confirm cable adapter is positioned as shown below. Insulation may extend beyond adapter as long as both checks below are confirmed.

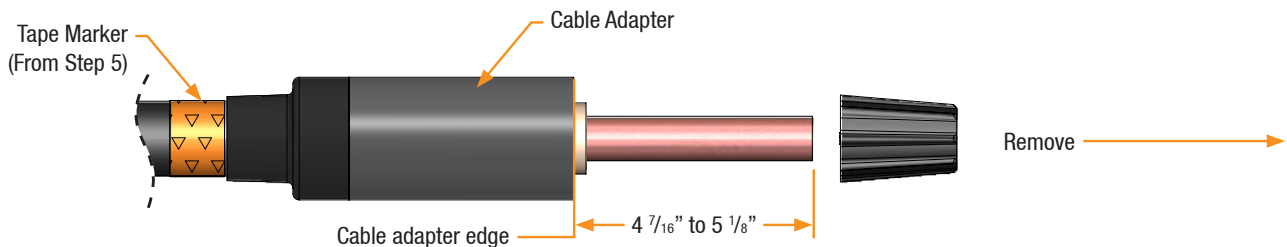

- CHECK:** Confirm that edge of tape marker is flush with end of cable adapter as shown.
- CHECK:** Confirm that dimension from end of conductor to cable adapter edge satisfies criteria shown above.

# 10.1

## Installing Lug

### For Crimp Connectors

- Clean conductor of any debris. For aluminum conductor, wire brush and immediately insert lug onto conductor. Slide lug until the conductor is fully seated within the lug barrel.
- Rotate lug so that spade is parallel to the contact face of the bushing or mating part as shown.
- Select correct tool and die using crimp chart supplied with lug. Crimp lug (min. number indicated in crimp chart) starting just below knurl line adjacent to pad. Carefully wipe any excess inhibitor from lug and cable insulation.

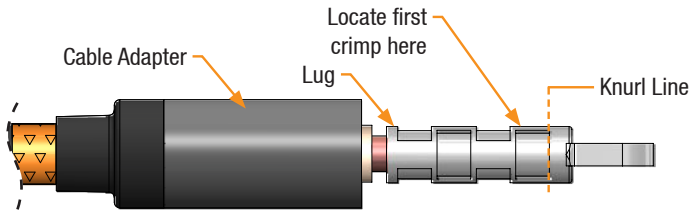
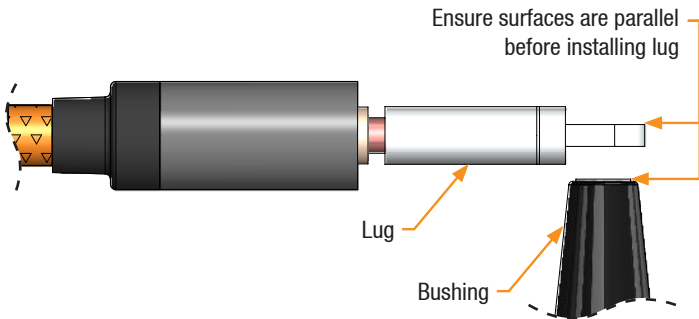

### For Shear Bolt Connectors

- For **Range Taking Lugs**: Refer to lug bag for centering ring selection. Install centering ring into barrel opening.
  - Clean conductor of any debris. For aluminum conductor, wire brush and immediately insert lug onto conductor. Slide lug until the conductor is fully seated within the lug barrel.
  - Rotate lug so that spade is parallel to the contact face of the bushing or mating part as shown. Hand tighten shear bolts in tightening sequence shown.
- NOTE:** Your lug may have fewer bolts, but sequence is tightening bolts closest to cable entrance and working way towards spade.
- Fully tighten bolts in tightening sequence shown. The bolt will break free when the required torque value is reached.

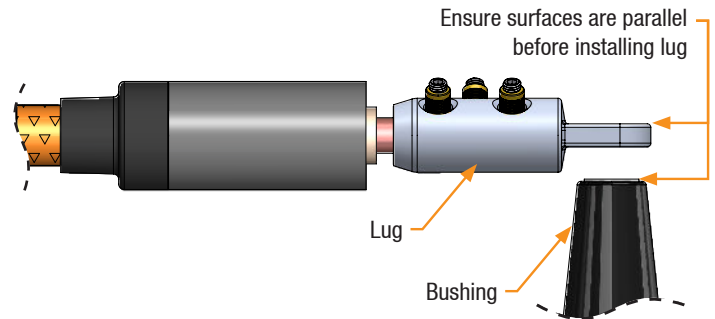

### Bolt Tightening Sequence

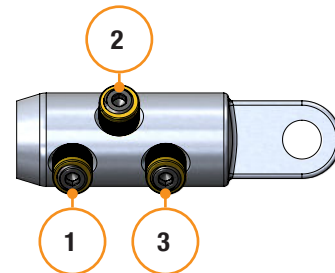

# 10.2

## Installing Lug

- After installing lug, confirm distance from lug end to the cable adapter does not exceed dimension shown.



**WARNING: Do not exceed maximum dimension shown.**

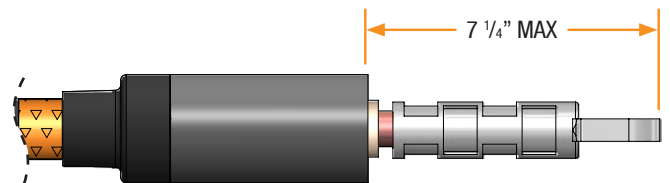

11

**Installing Elbow**

- A. Clean and lubricate (using supplied or approved silicone grease) entire surface of cable adapter and cable entrance of elbow.
- B. Without moving cable adapter, push elbow onto cable adapter and slide until lug is fully seated inside elbow. Confirm cable adapter has not shifted by observing tape marker. Cable adapter and tape marker should be aligned as they were in the "Installing Cable Adapter" step.



**WARNING:** Confirm cable adapter does not shift from proper positioning during installation of elbow housing.



**WARNING:** Confirm the lug has fully seated into housing as shown.

**NOTE:** If equipped with a capacitive test point, ensure test point is facing outwards for accessibility.

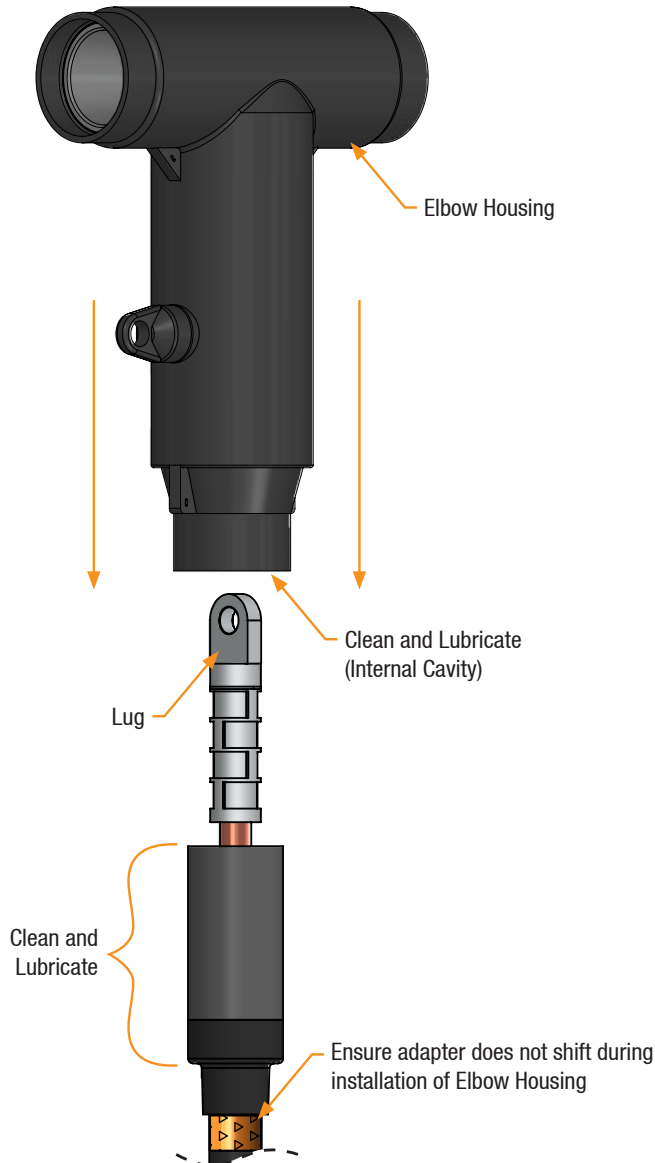
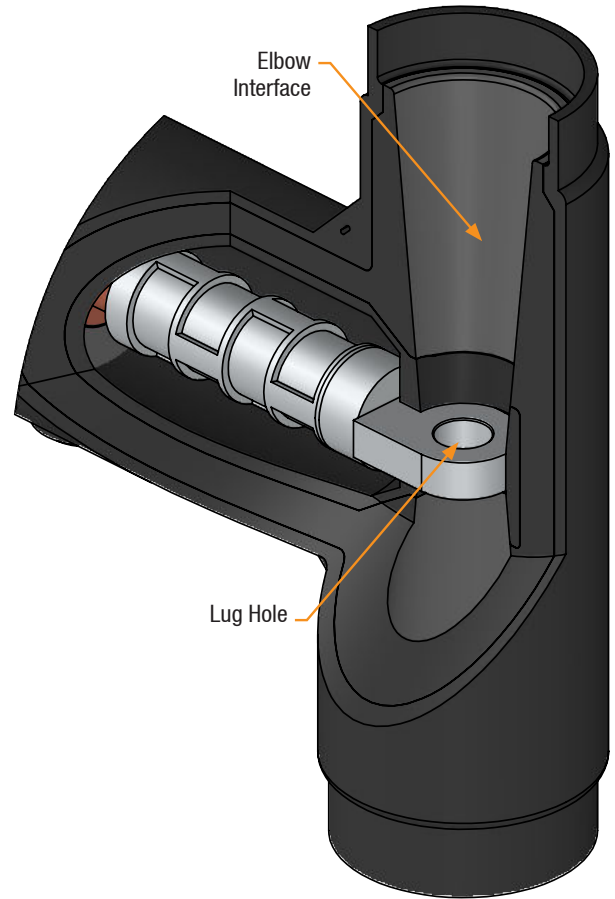

# 12

## Mounting Elbow

**NOTE:** For installations where the Elbow is either installed but temporarily kept in an unmounted position; or installations where the Elbow must be removed from the bushing/mating component, refer to **TEMPORARY/ALTERNATIVE INSTALLATION ADDENDUM** at the end of these instructions for specific guidance.

A. Hand-tighten stud into the appropriate mating part or bushing.

**WARNING:** The stud **MUST** fully thread on. No threads should be visible on the bushing (male) interface. If any threads are visible, confirm correct stud is being used and check for cross-threading/thread damage.

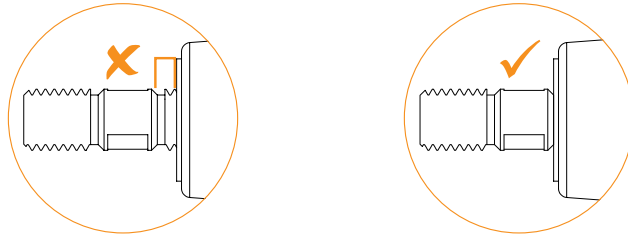

- B. Clean and lubricate (using supplied or approved silicone grease) interface of elbow and interface of mating part or bushing.
- C. Place one hand on the power cable directly below elbow and one hand on the body of the elbow. Lifting together, push elbow onto mating part, lining up the hole in the lug with the stud on the mating part.

**CHECK:** Observe positioning of elbow/cable adapter/lug assembly, before and after mounting, to determine if the lug has shifted position. If a shift is observed repeat assembly to restore correct positioning and re-do this step.

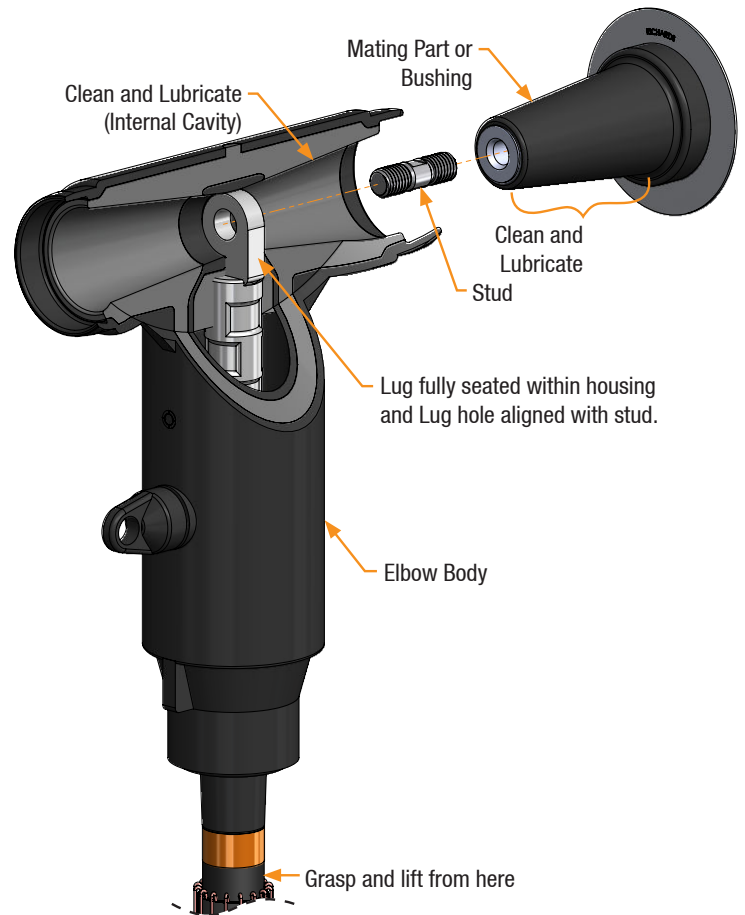



13

Installing Mating Component

- A. Clean and lubricate (using supplied or approved silicone grease) the remaining elbow interface and mating part interface as shown.



**WARNING: Ensure stud is through lug hole as shown before tightening assembly.**

- B. Insert mating part, engage threads, and hand-tighten.
- C. **For Insulating Plugs:** Engage hex nut and tighten to 50-60 ft lbs using appropriate tool. Lubricate interior of insulating plug cap and push on to install.  
**For all other mating parts:** Install mating part per manufacturer instructions.

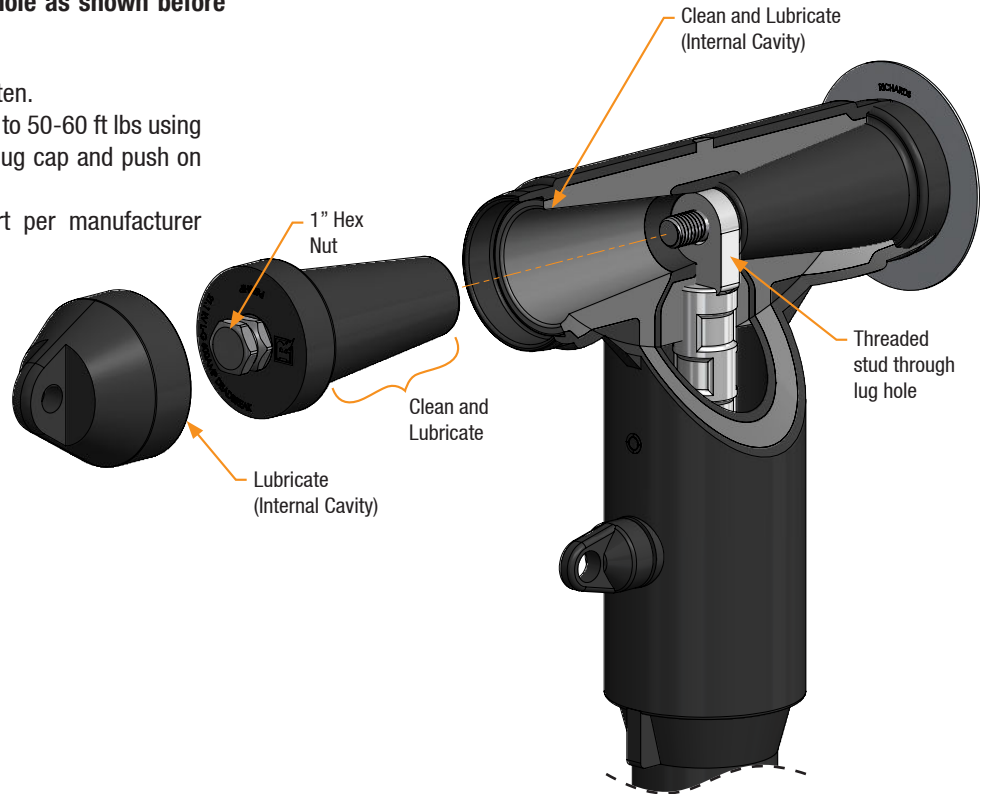

**14**

**Applying Sealing Mastic**

**For Strap/Wire Shielded Cable**

- A. Apply sealing mastic over previously applied mastic and on top of folded back neutral wires by stretching and wrapping with light tension.
- B. Apply sealing mastic by stretching and wrapping with light tension fully around nose of cable adapter for a width of 1" as shown below.

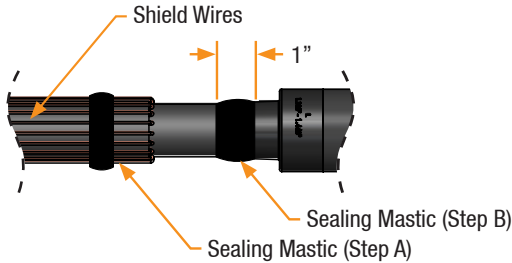

**For Metallic Tape/LC Shielded Cable**

- A. Apply sealing mastic over previously applied mastic and on top of solder block by stretching and wrapping with light tension.
- B. Apply sealing mastic by stretching and wrapping with light tension fully around nose of cable adapter for a width of 1" as shown below.

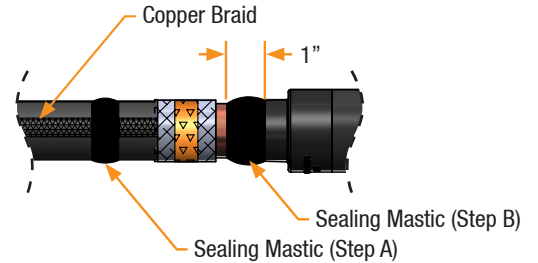

**15**

**Applying Jacket Seal Tube**

- A. Beginning with the side closer to the cable adapter, deploy the jacket seal in area shown below ensuring both mastics are completely covered.

**For Strap/Wire Shielded Cable**

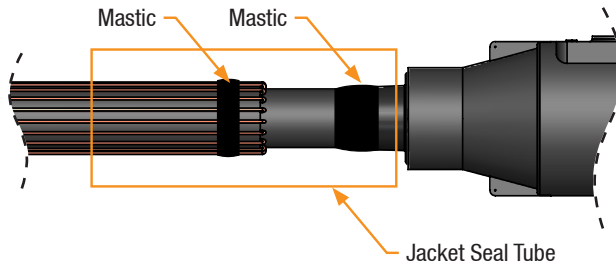

**For Metallic Tape/LC Shielded Cable**

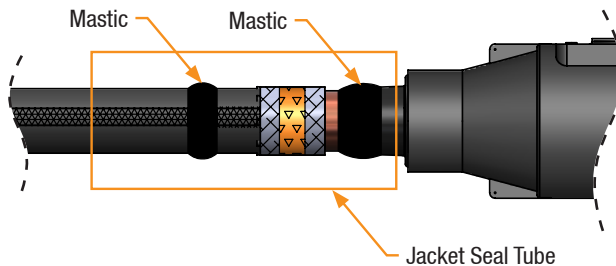

**16****Installing Drain Wire and Grounding Metallic Shield****For Strap/Wire Shielded Cable**

- Secure neutrals with binding wire or zip tie 1" from jacket seal tube.
- Insert one end of a piece of wire (#14 AWG copper or larger) through one of the available grounding eyes and twist to make a small loop. Be sure not to damage grounding eye.
- Connect other end of wire to shield wires.
- Ground the cable shield according to appropriate/approved practice.

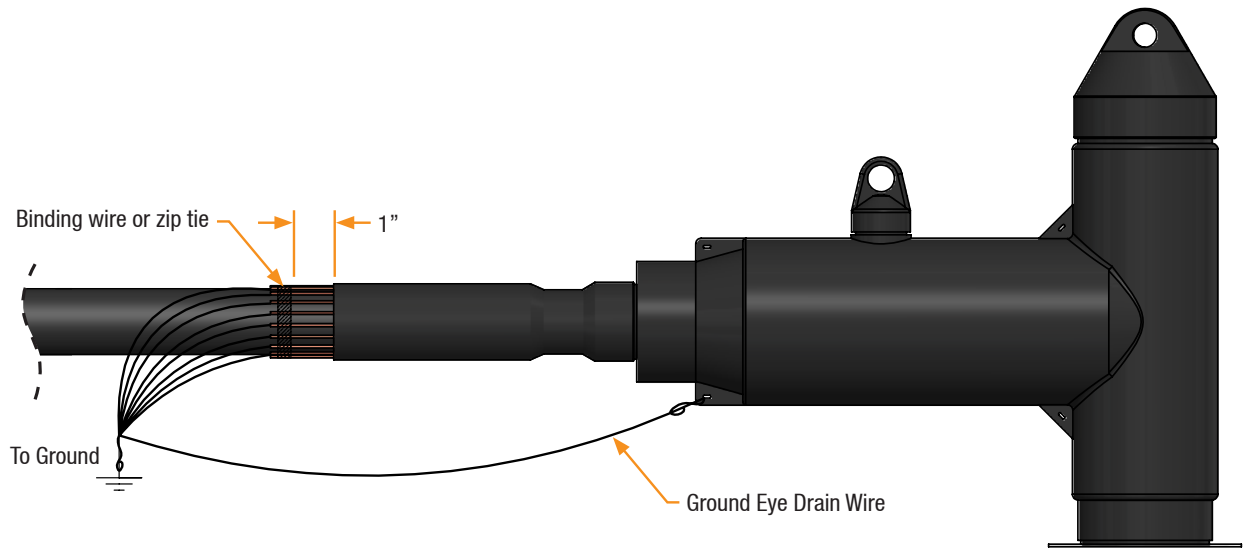
**For Metallic Tape/LC Shielded**

- Secure copper braid with binding wire or zip tie 1" from jacket seal tube.
- Insert one end of a piece of wire (#14 AWG copper or larger) through one of the available grounding eyes and twist to make a small loop. Be sure not to damage grounding eye.
- Connect other end of wire to copper braid.
- Ground the cable shield according to appropriate/approved practice.

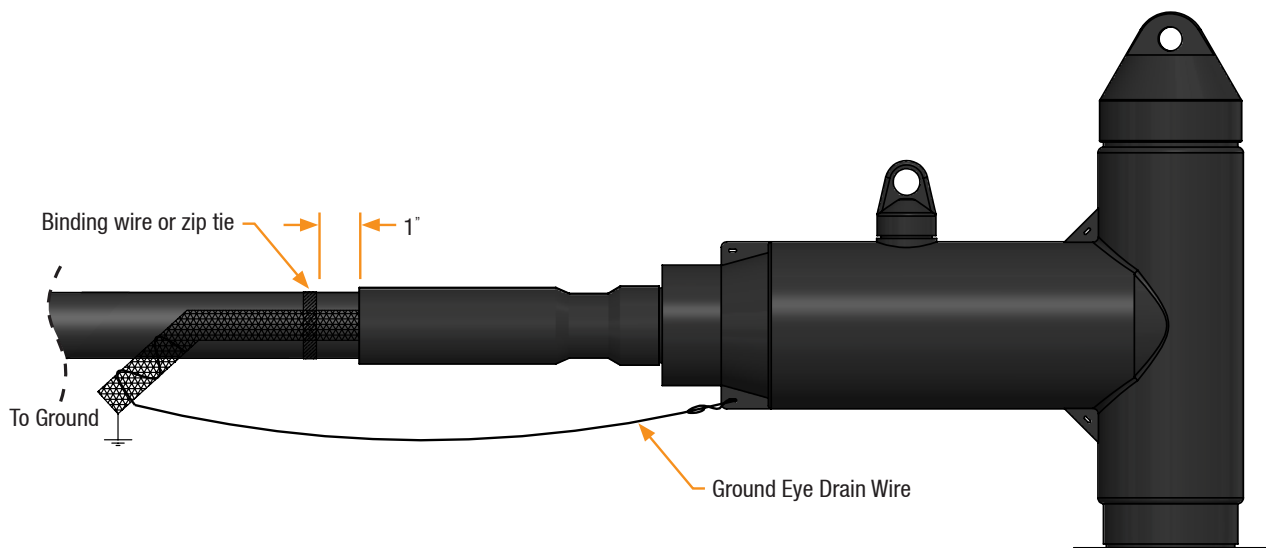
**Installation Complete**

## TEMPORARY/ALTERNATIVE INSTALLATION ADDENDUM:

For installations where the Elbow is either installed but temporarily kept in an unmounted position; or installations where the Elbow must be removed from the bushing/mating component (equipment changeout, cable testing, etc), you **MUST** follow the below guidelines:

- A. Move the cable and Elbow together to avoid disrupting proper positioning between the cable, lug and elbow. Even a Cold Shrink product can be dislodged when moving.
- B. Install appropriate mating components to keep exposed interfaces clean/dry and to capture and maintain correct lug positioning in this temporary configuration. If no mating component is available, you must bag the Elbow to keep interfaces clean/dry and utilize an approved method for maintaining proper lug positioning.
- C. Visually re-confirm alignment and that the lug is fully seated before proceeding with mounting elbow to bushing/mating component.

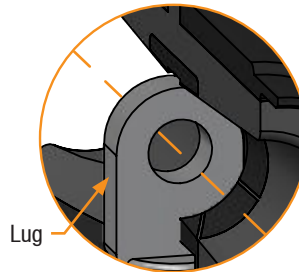

Lug fully seated

- D. After visually confirming alignment, choose a fixed point on the cable (apply a tape marker if necessary) and fixed point on the Elbow (e.g. grounding eyelet) and measure the distance. After performing mounting and starting 2-3 turns of thread engagement, re-measure and confirm distance has not changed more than 3/4". If distance changes by more than 3/4", stop installation and re-align Elbow/lug/cable before proceeding.