

# Product Specifications

## 15/25/28kV 600A Deadbreak Insulated Parking Bushing

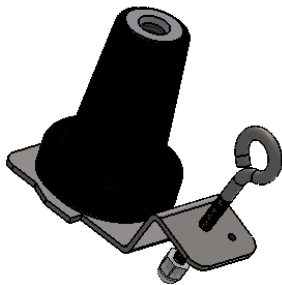
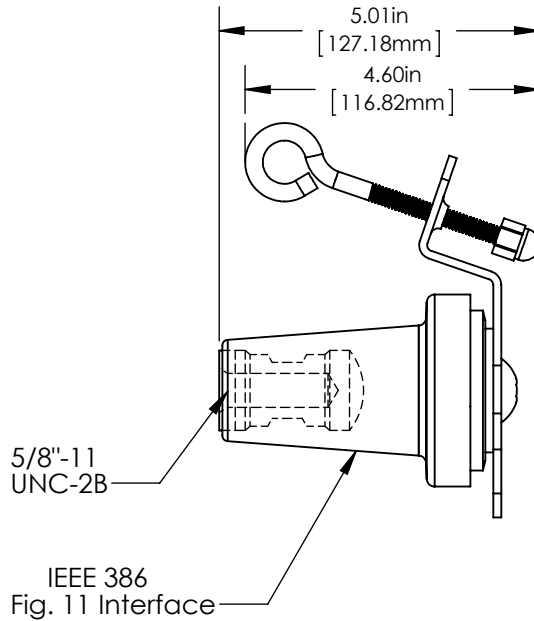

Richards 15/25/28kV Deadbreak 600A Insulating Parking Bushing provides an easy way to isolate 15/25/28kV 600A elbows.

The parking bushing is fully shielded and features an epoxy plug mounted to adjustable stainless steel bracketry.

### Product Ratings

Operating Voltage	16.2kV
Impulse Withstand	140kV BIL
AC Withstand	45kV
DC Withstand	84kV
Partial Discharge	22kV CEV

Richards 15/25/28kV Deadbreak 600A Insulating Parking Bushing was designed and validated against the following industry standards:

- ANSI/IEEE Std. 386: For Separable Insulated Connector Systems
- ANSI C119.4: For Electric Connectors
- IEEE Std. 592: For Exposed Semiconducting Shields