

Product Specifications

15/25 kV Aluminum Stud

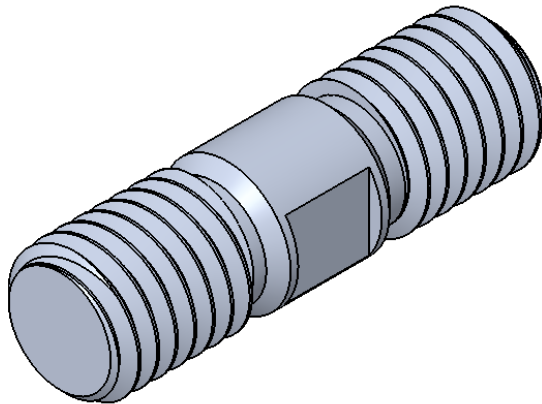
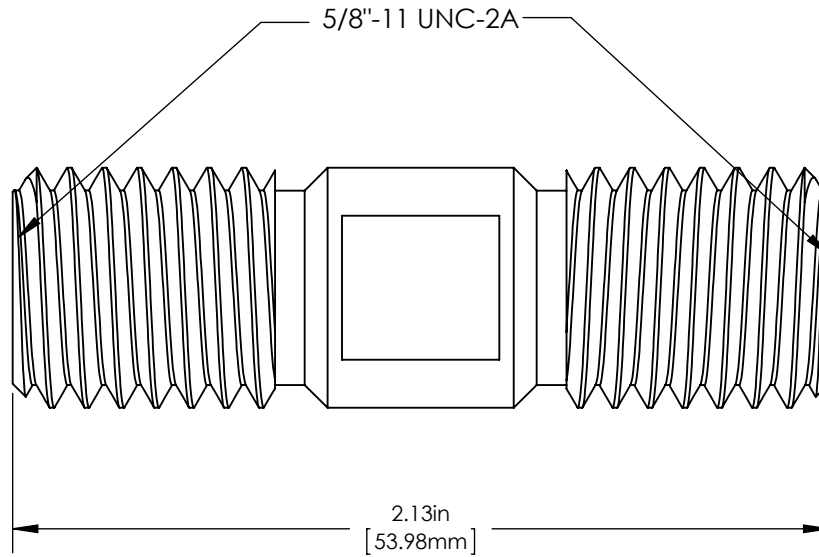

Richards 15/25 kV Aluminum Stud is used to thread together two IEEE 386 Fig. 11 interfaces.

The stud threads are 5/8"-11 UNC-2A and meet the dimensional requirements of IEEE 386.