

Product Specifications

25/28 kV R-800, Male

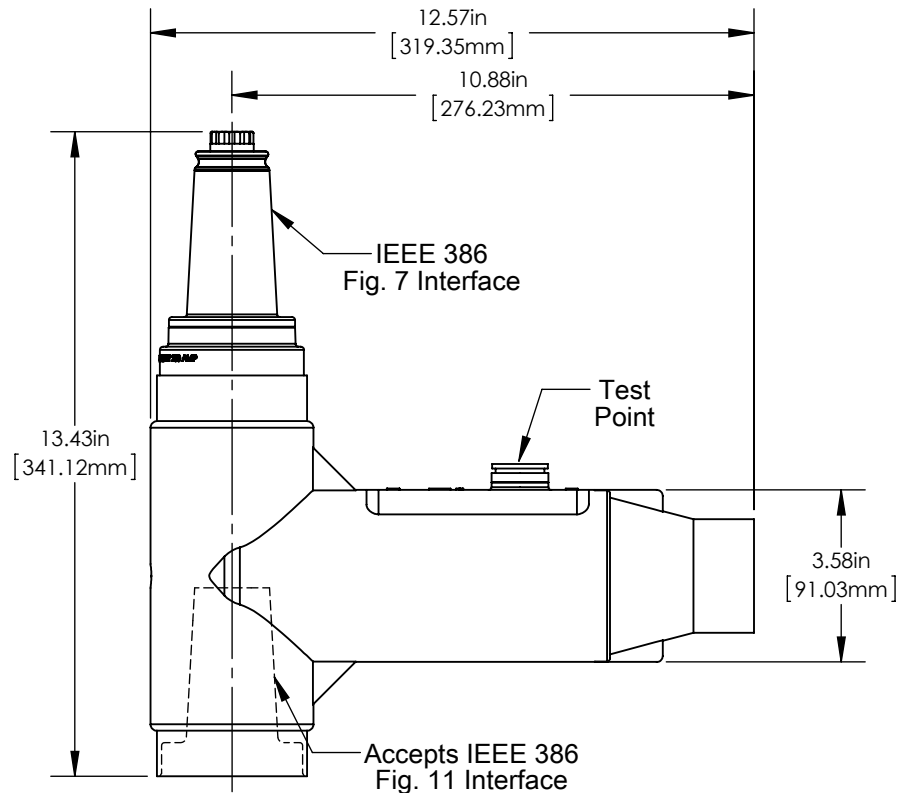

Richards 25/28 kV R800 (628MT) is a 600A elbow with a 200A loadbreak tap molded into the body. This combination design reduces the number of components, time, and effort required for installation.

The R800 male version is fully shielded and features a male fastener for assembly to the bushing.

Product Ratings

Operating Voltage	16.2 kV 28 kV L-L
Impulse Withstand	140 kV BIL
AC Withstand	45 kV
DC Withstand	84 kV
Partial Discharge	22 kV CEV

Richards 25 kV R-800, Male (628MT) was designed and validated against the following industry standards:

- ANSI/IEEE Std. 386: For Separable Insulated Connector Systems
- ANSI C119.4: For Electric Connectors
- IEEE Std. 592: For Exposed Semiconducting Shields

Switching & Fault Close Testing to 25 kV Levels