

Installation Instructions

600 Amp & 900 Amp Deadbreak Elbow Connectors for 35kV Voltage Class

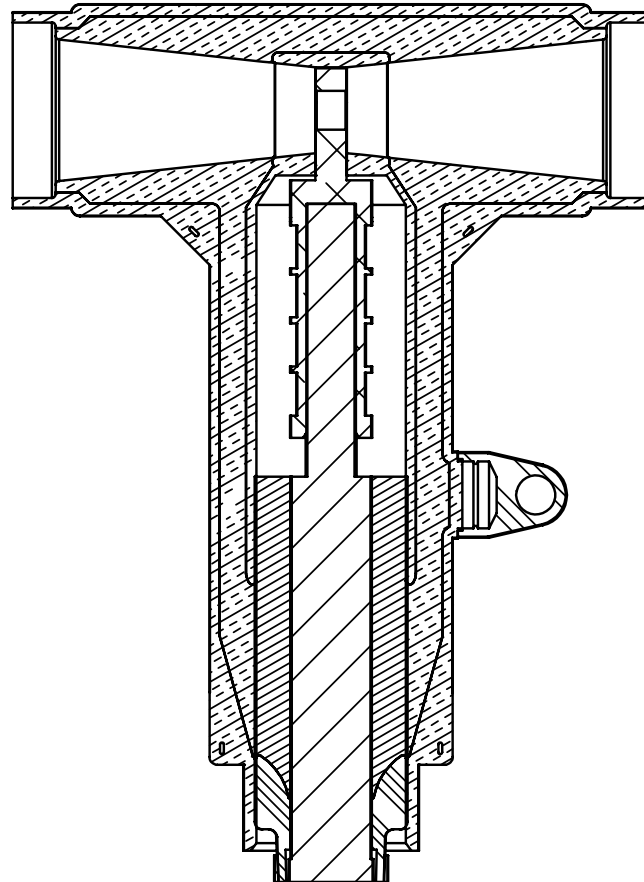

Applicable Catalog Prefix

63LCN-
63LCT-
73LCN-
73LCT-
93LCN-
93LCT-



WARNING

- System must be de-energized during installation or future operation of this product or its components.
- Do not touch or move energized connectors or components by hand.
- Excess distortion of the assembled connector may result in its failure.
- Failure to follow these instructions will result in damage to the connector and serious or fatal injury.
- This product should only be installed and/or operated by trained personnel in accordance with normal and safe work procedures.
- Variations in equipment or configuration or work procedures may not be covered in these instructions.
- Please contact Richards Manufacturing for any additional questions.

KIT CONTENTS

Standard Deadbreak Elbow kits may include the following. Custom kits may vary.
Check package contents to be sure they are complete, undamaged, and properly sized for the application.

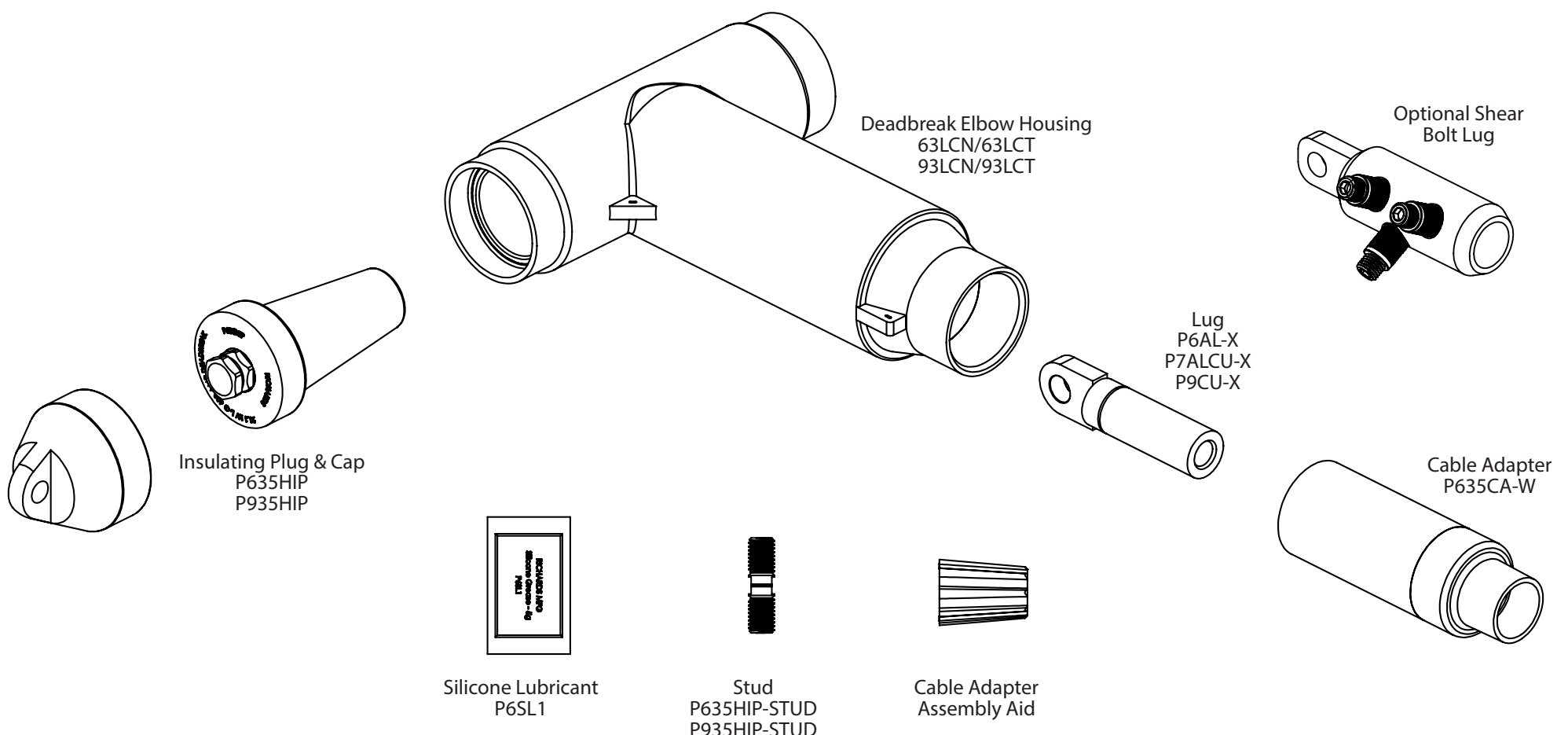

Installation Instructions

TIP: Use to-scale cable cutback template on last page as aid to prepare cable.

NOTE: Certain items used such as mastic, PVC tape, shrink tube, etc. may not be included.

Step 1: Positioning the Cable

- A. Straighten cable end.
- B. Train cable into final position.
- C. Cut cable to dimensions shown.
- D. Clean cable jacket up to 24" from end of cable.

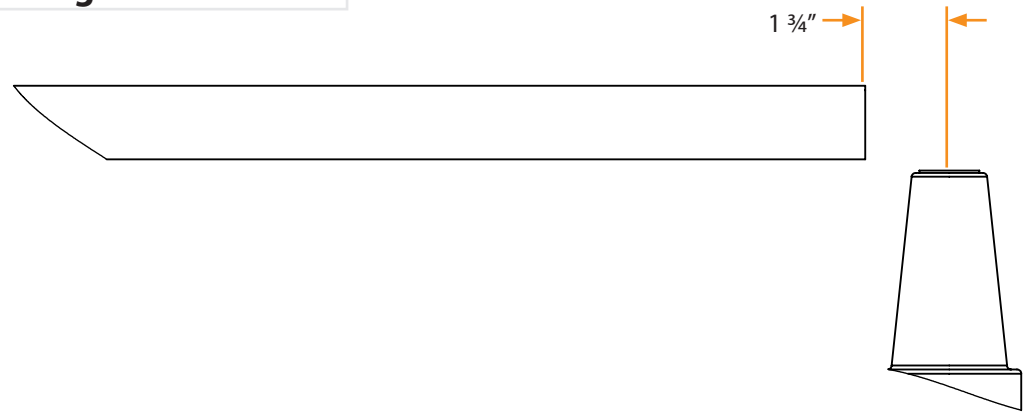

Step 2: Exposing Cable Shielding

- A. Remove cable jacket to dimensions shown.
- B. Abrade area as shown.

NOTE: Cable Shielding may be wires, straps, metallic tape, or LC tape. (Wires shown as example)

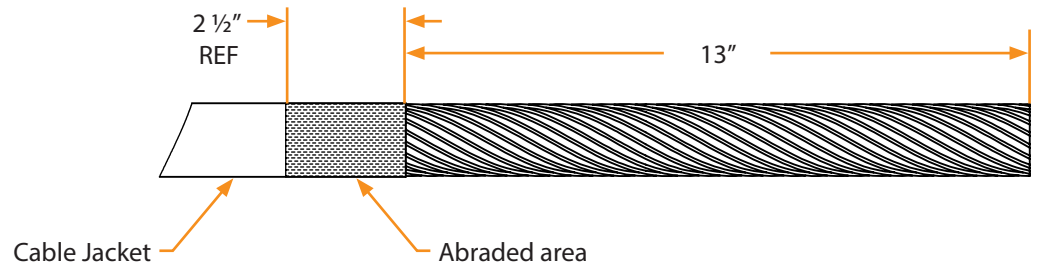

Step 3: Applying Sealing Mastic

- A. Apply sealing mastic at position shown by stretching and wrapping with light tension fully around outer jacket.

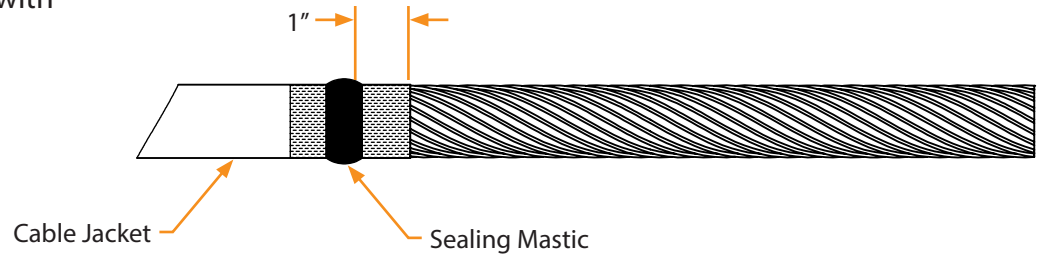

Step 4: Exposing Cable Semi-Conductive Shield

- A. Fold back strap/wire shields and press firmly into sealing mastic.
- B. Secure strap/wire shields to cable with PVC tape as shown.

- A. Wrap one winding of PVC tape at dimension shown to secure metallic shield.
- B. Remove metallic shield up to PVC tape.

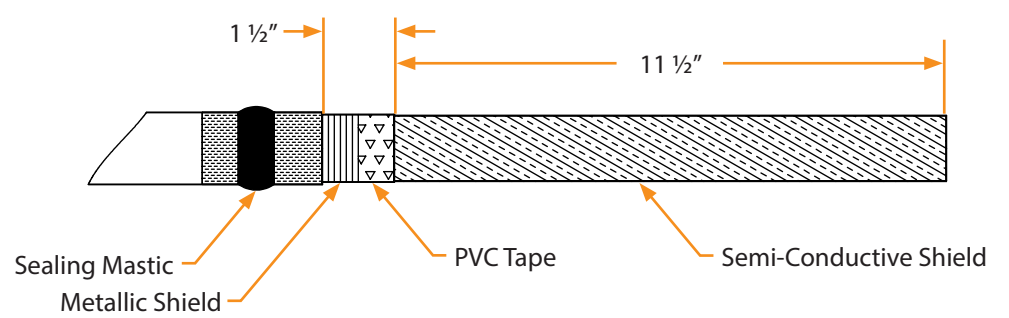
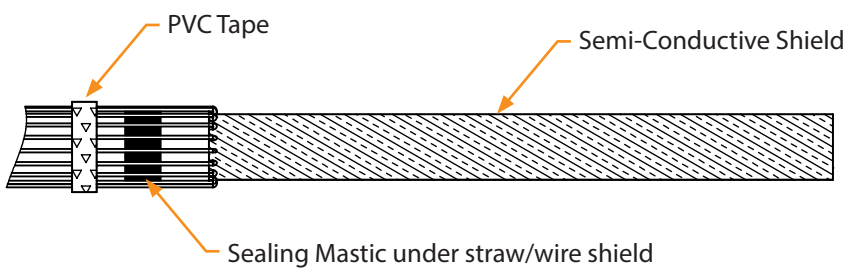

Step 5: Exposing Cable Insulation

For Strap/Wire Shielded Cable

- A. Remove semi-conductive shield to dimensions shown.
- B. Place PVC tape marker at dimension shown.

For Metallic Tape Shielded/LC Shielded

- A. Remove semi-conductive shield to dimensions shown.
- B. Check that tape from Step 4 is 1" from the edge of the semi-conductive shield as it will serve as a marker.

WARNING: Do not nick or cut the cable insulation.

WARNING: Do not nick or cut the cable insulation.

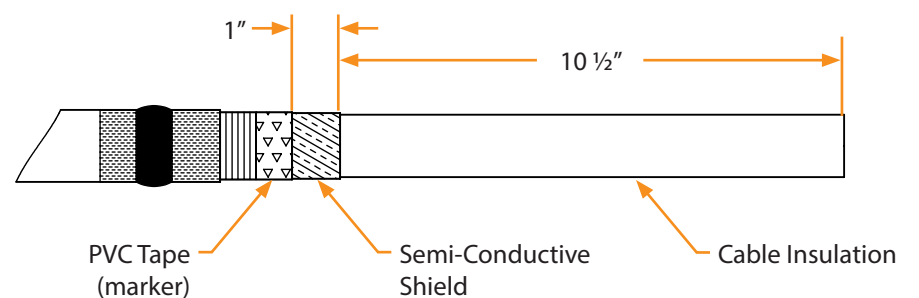
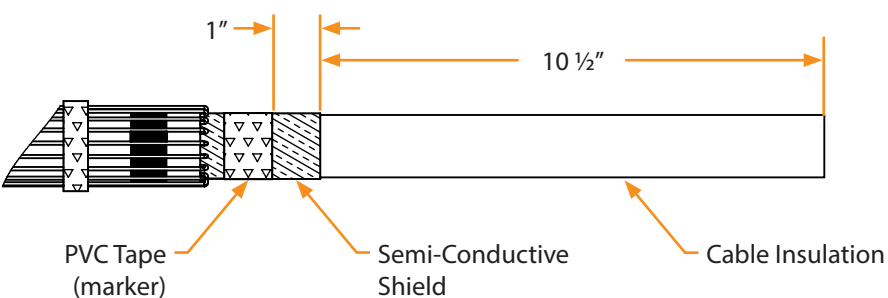

Installation Instructions

For Strap/Wire Shielded Cable Go to Step 7

Step 6: Preparing Metallic Shield

- A. Position copper braid so that solder block rests on the sealing mastic.
- B. Wrap copper braid around metallic tape shield as shown.

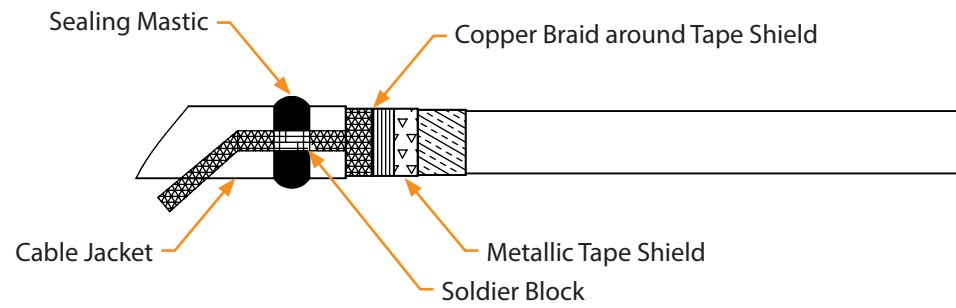

- C. Wrap constant force spring over wrapped portion of copper braid.
- D. Wrap 2 layers of PVC tape over constant force spring.
- E. Press solder block into sealing mastic.
- F. Secure braid to cable with PVC Tape.

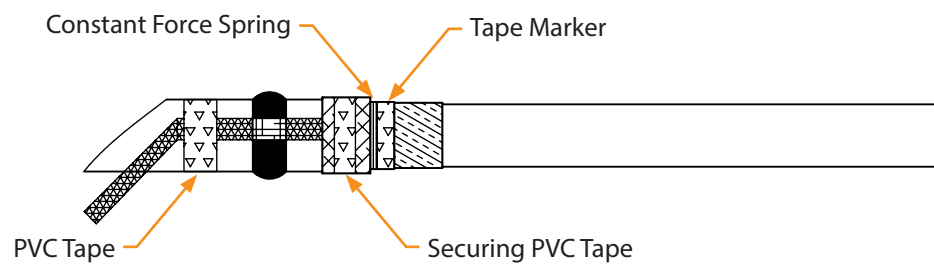

Check: Confirm that solder block is aligned with sealing mastic.

Step 7: Exposing the Conductor

- A. **For Shear Bolt Connectors:** Remove cable insulation referring to instructions provided with lug for insulation cutback dimension.
- For Crimp Connectors:** Remove cable insulation as shown.
- B. Clean insulation with approved cleaning wipes by wiping only in direction shown.

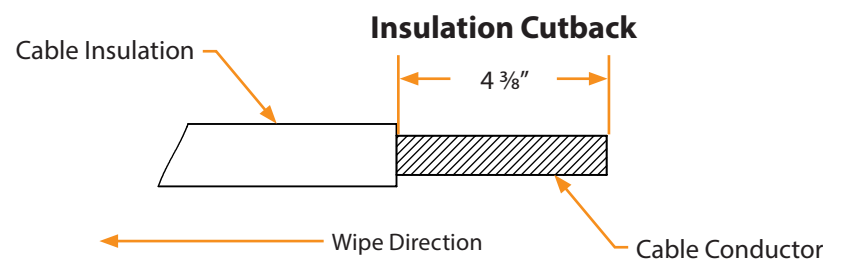

WARNING: Do not nick or cut conductor strands.

NOTE: Confirm all dimensions with To-Scale Cable Cutback Template on last page before proceeding.

Step 8: Parking Shrink Tube

- A. Slide heat or cold shrink tube onto cable as shown.

Strap/Wire Shielded

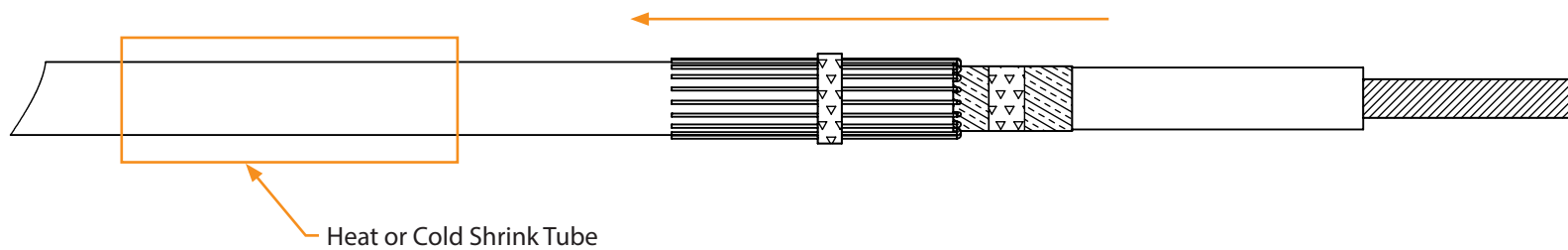

Metallic Tape Shielded/LC Shielded

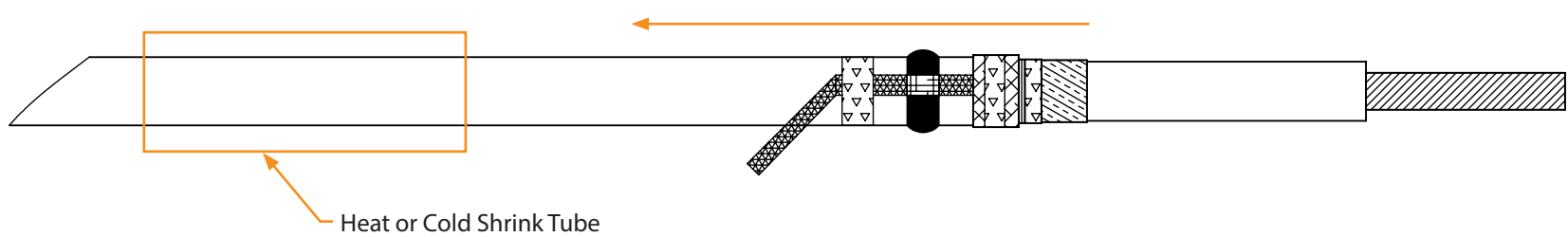

Installation Instructions

Step 9: Installing Cable Adapter

- Slide cable adapter assembly aid up to insulation.
- Apply silicone lubricant to cable insulation, cable adapter assembly aid, and inside of cable adapter as shown.
- Slide cable adapter onto cable until the cable adapter sits flush with the leading edge of the tape marker as shown.

NOTE: Cable adapter size F does NOT use a cable adapter assembly aid.

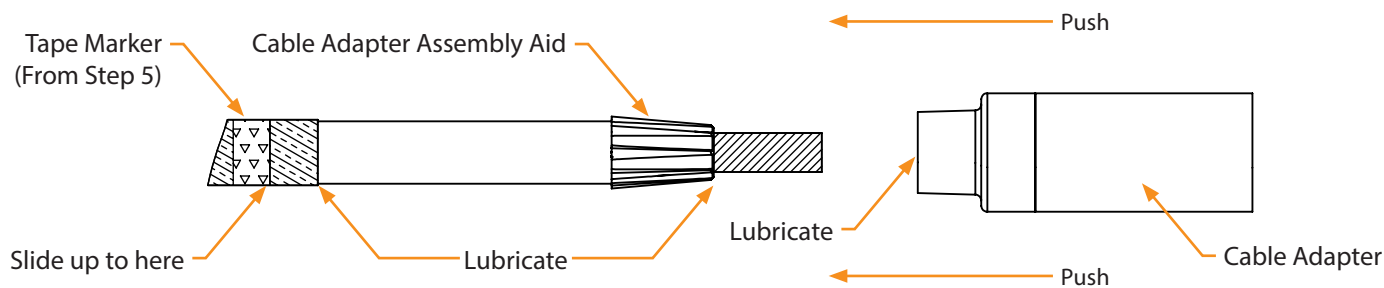

- Remove cable adapter assembly aid.
- Confirm cable adapter is positioned as shown below.

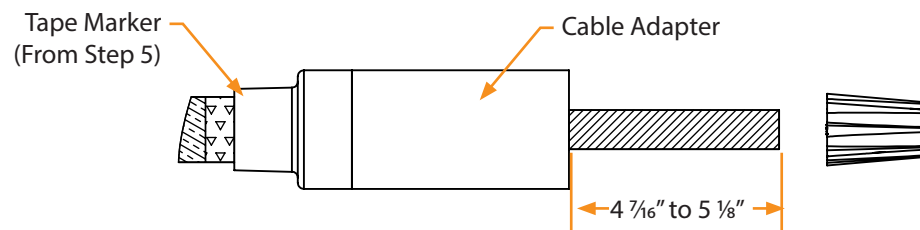

Check: Confirm that edge of tape marker is flush with end of cable adapter as shown.

Check: Confirm that exposed conductor dimension satisfies criteria shown above.

Step 10: Installing Lug

- Clean conductor of any debris. For aluminum conductor, wire brush and immediately insert lug onto conductor. Slide lug until the conductor is fully seated within the lug barrel.
- For Shear Bolt Connectors:** Install lug using separate instructions provided with lug.
For Crimp Connectors: Select correct tool and die using crimp chart supplied with lug. Crimp lug (min. number indicated in crimp chart) starting just below knurl line adjacent to pad. Carefully wipe any excess inhibitor from lug and cable adapter surface.

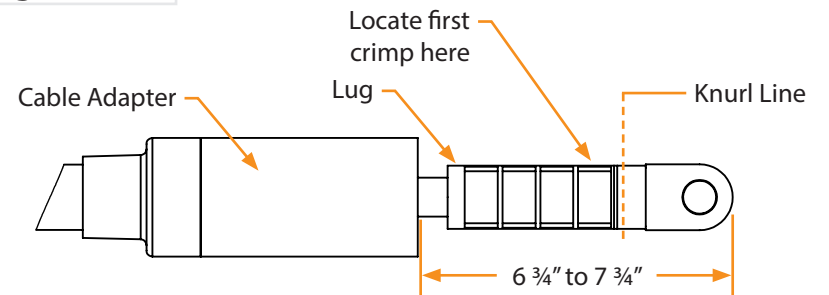

After installing lug, confirm that the distance from the end of the lug to the cable adapter is within range shown above.

Step 11: Applying Sealing Mastic

For Strap/Wire Shielded Cable

- Apply sealing mastic on top of previously applied sealing mastic (See Step 3) by stretching and wrapping with light tension fully around.
- Apply sealing mastic by stretching and wrapping with light tension fully around on base of cable adapter for a width of 1" as shown below.

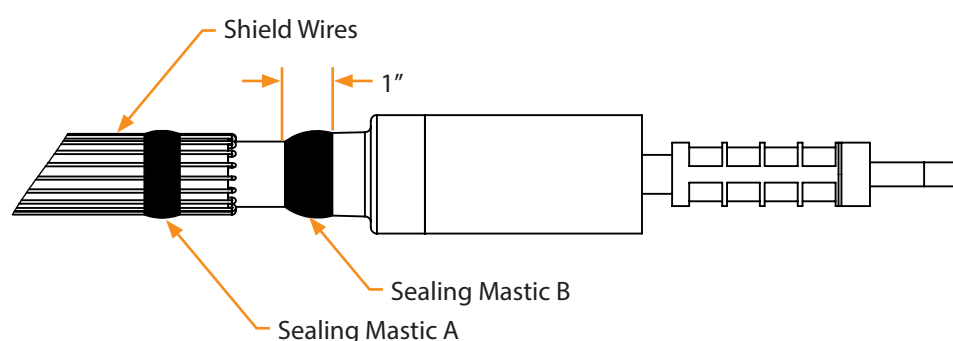

For Metallic Tape Shielded/LC Shielded

- Lay copper braid along cable.
- Apply sealing mastic by stretching and wrapping with light tension around solder block.
- Apply sealing mastic by stretching and wrapping with light tension fully around on base of cable adapter for a width of 1" as shown below.

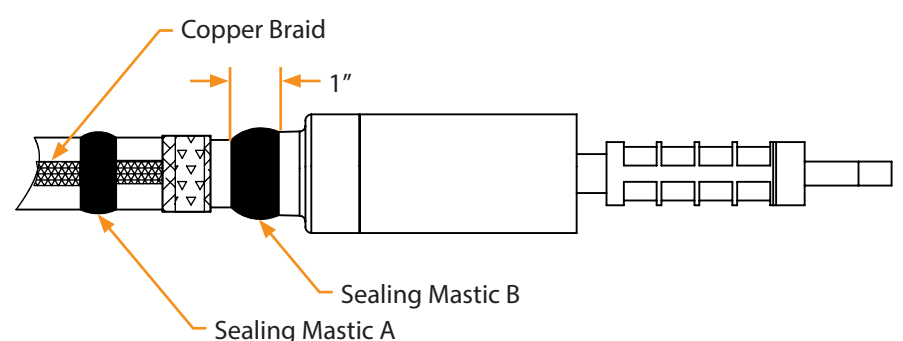

Installation Instructions

Step 12: Applying Shrink Tube

- Slide seal tube into position as shown.
- Shrink down seal tube starting from cable adapter side.

Strap/Wire Shielded

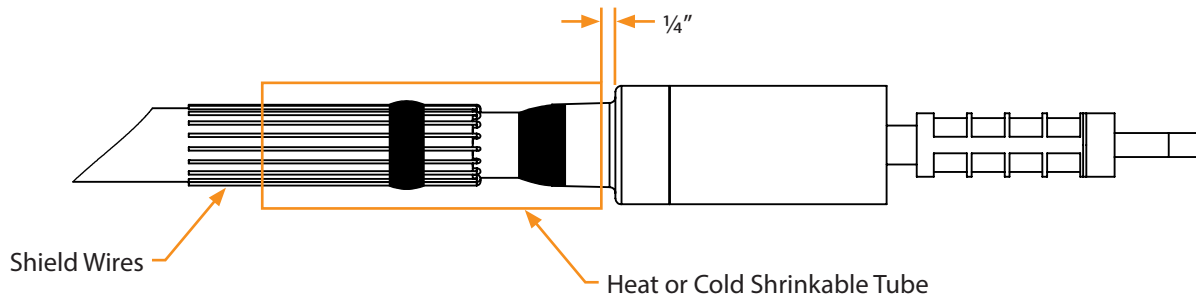

Metallic Tape Shielded/LC Shielded

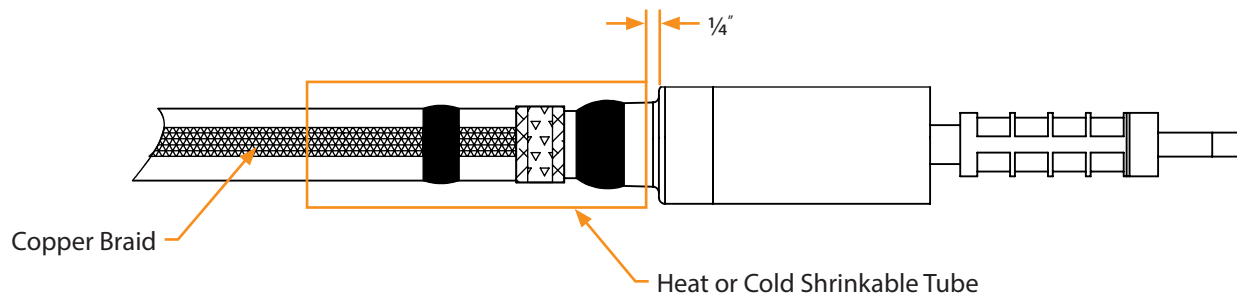

Step 13: Installing Elbow Housing

- Lubricate entire surface of cable adapter and cable entrance of elbow.
- Install elbow onto cable adapter and push until the lug is fully seated inside the elbow.

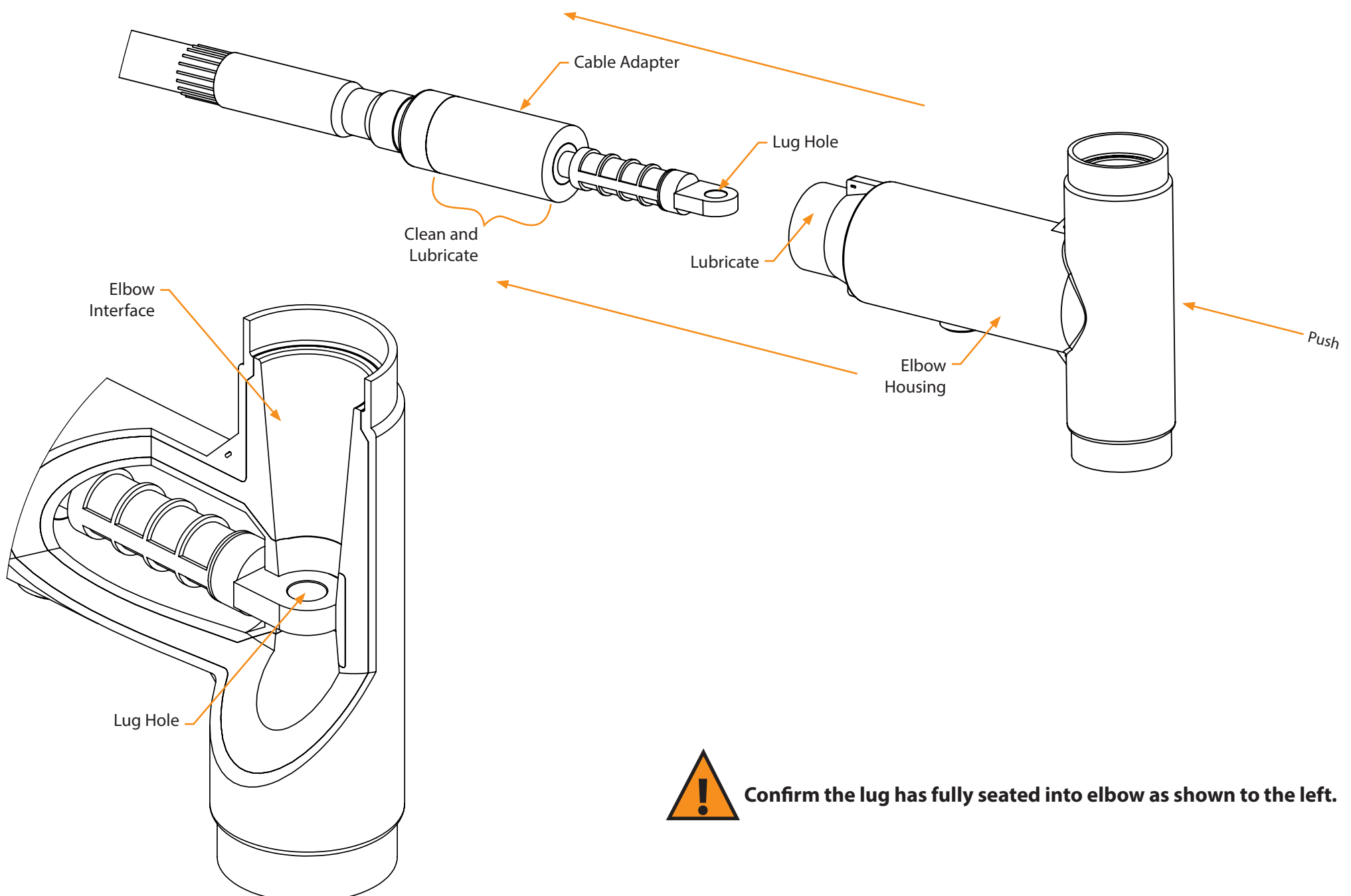

Installation Instructions

Step 14: Mating Part Installation - Side 1

- Hand-tighten stud into the appropriate mating part or bushing.
- Clean and lubricate elbow and mating part interface as shown.
- Push elbow onto mating part, lining up the hole in the lug with the stud on the mating part.

Side 1 interface may be one of the following:

- Apparatus Bushing
- Connecting Plug
- Insulating Plug

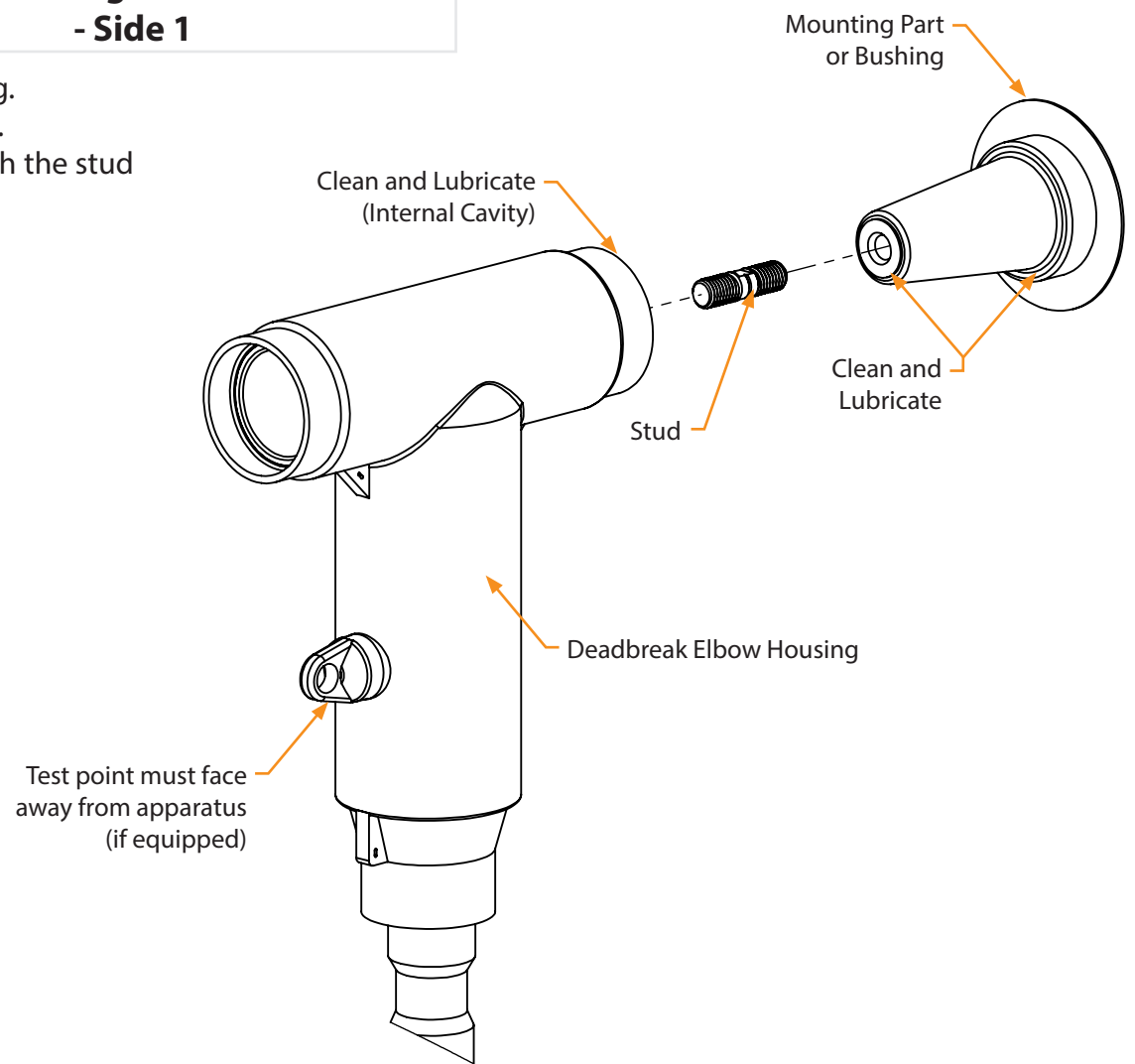

Confirm stud is through lug hole as shown below.

Step 15: Mating Part Installation - Side 2

- Clean and lubricate the elbow and entire surface of mating part.
- Insert mating part into elbow
- Engage threads and hand tighten.

Side 2 interface may be one of the following:

- Insulating Plug (Step 16, Option 1)
- Connecting Plug (Step 16, Option 2 or 3)

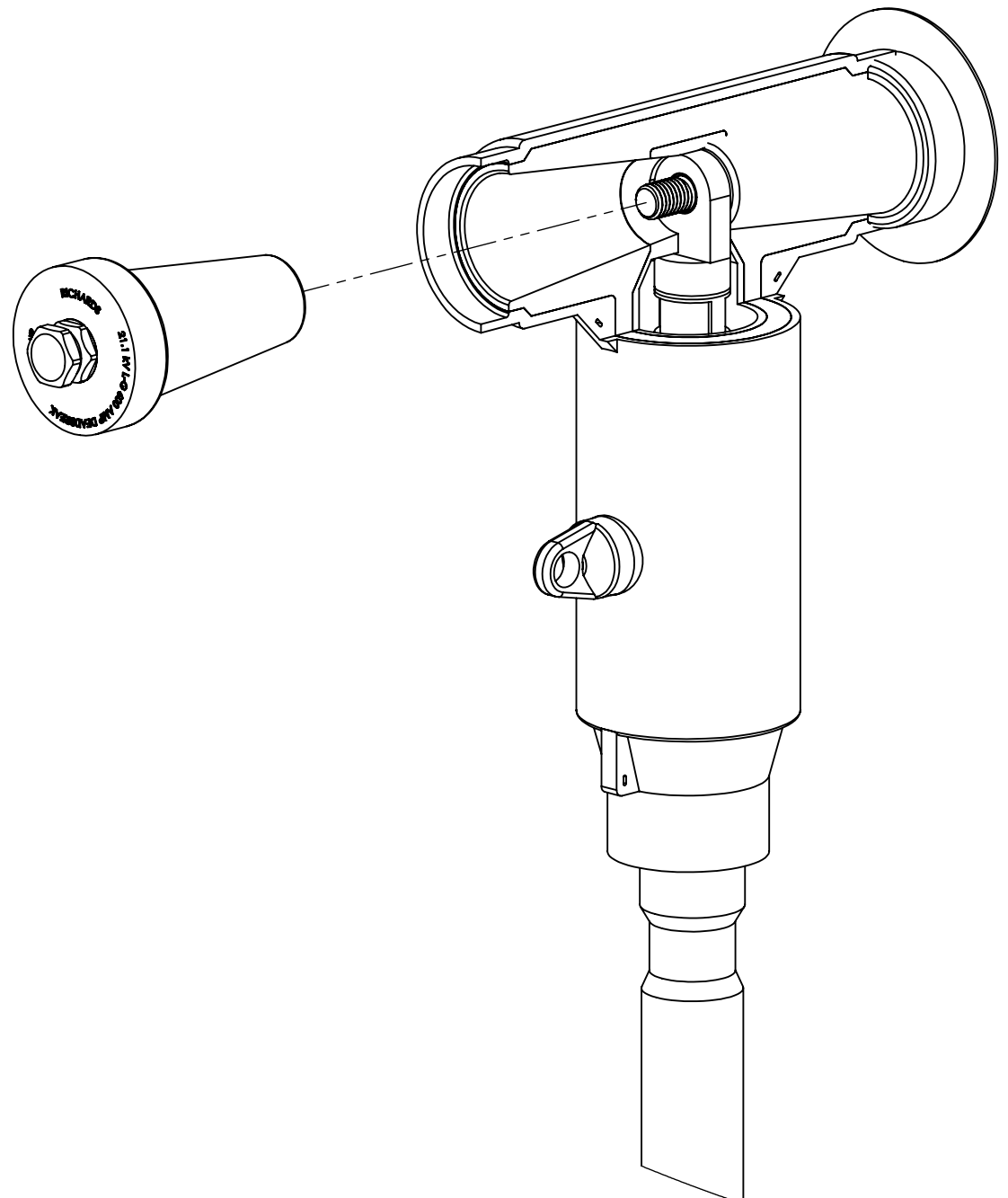

Installation Instructions

Step 16: Proper Tightening Procedure

Option 1-Installing an Insulating Plug

- A. Tighten nut to 50-60 ft. lbs.
- B. Lubricate inside surface of cap.
- C. Push cap onto plug until it snaps in place.

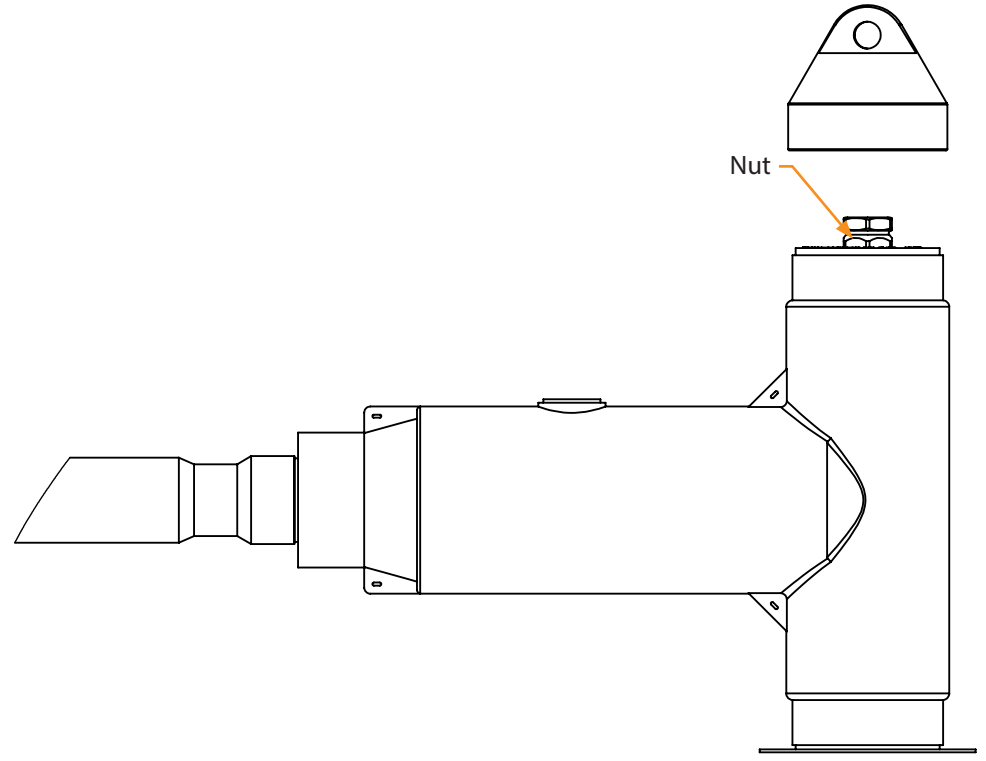

OR

Option 2-Installing a Connecting Plug

- A. Insert 3/8" hex tool into accessory and engage hex broach.
- B. Tighten to 50-60 ft. lbs. using appropriate tool.

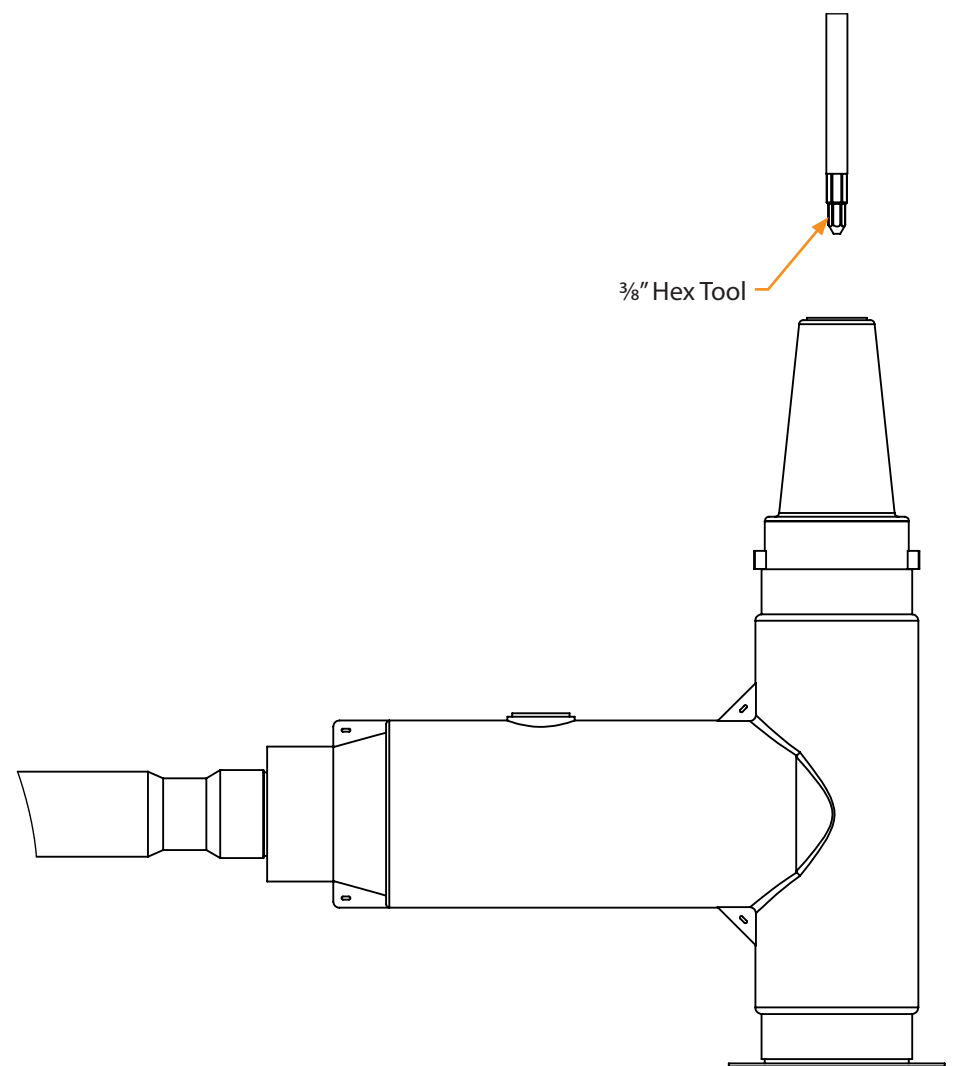

NOTE: If your mating part is not described above check for separate instruction sheets or contact Richards Manufacturing.

Installation Instructions

Step 17: Connecting Deadbreak Elbow to Ground

For Strap/Wire Shielded Wires

- Wrap 2 turns of binding wire 1" from heat or cold shrink tube and twist down firmly.
- Insert one end of a piece of wire (#14 AWG copper or larger) through one of the available grounding eyes and twist to make a small loop. Be sure not to damage hole.
- Wrap other end of wire around shield wires.
- The shield of the cable must be grounded according to appropriate utility practice.

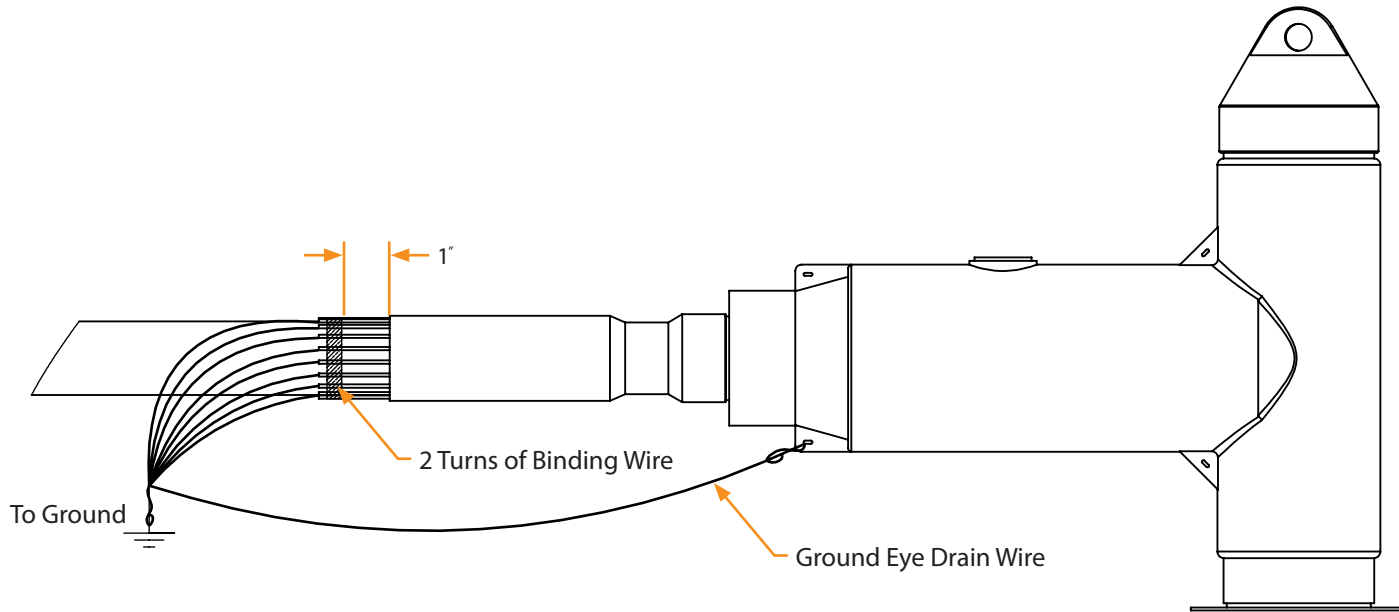

For Metallic Tape Shielded/LC Shielded

- Insert one end of a piece of wire (#14 AWG copper or larger) through one of the available grounding eyes and twist to make a small loop. Be sure not to damage hole.
- Wrap other end of wire around copper braid.
- The shield of the cable must be grounded according to appropriate utility practice.

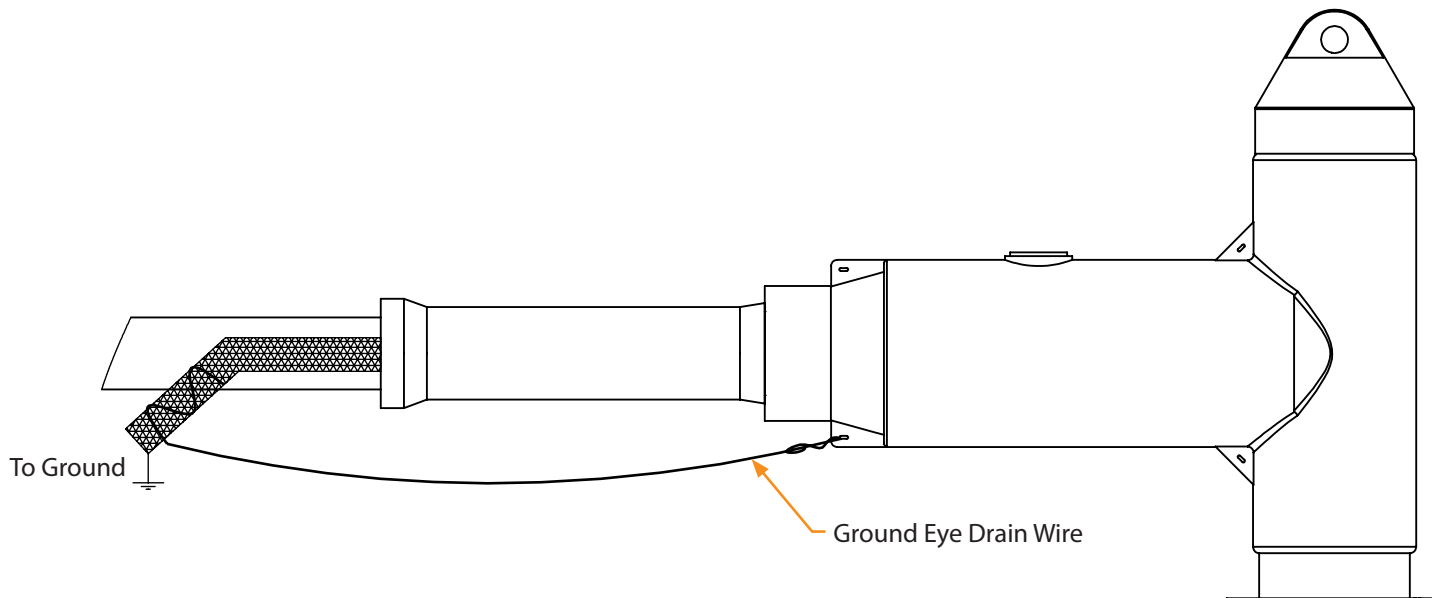

Installation Complete

Installation Instructions

SCALE 1:1

Strap/Wire Shielded Cables

Metallic Tape Shielded/LC Shielded

