

# Product Specifications

## 15/25 kV Reducing Tap Plug

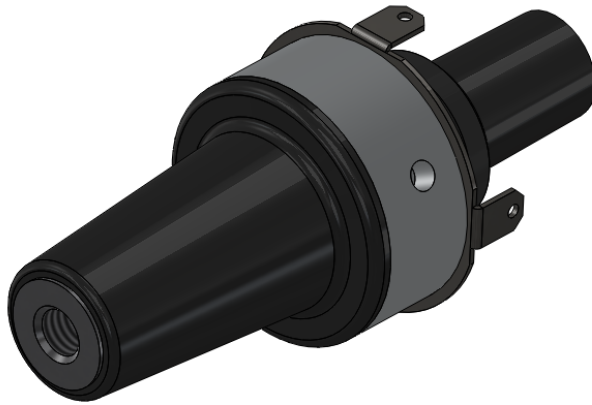
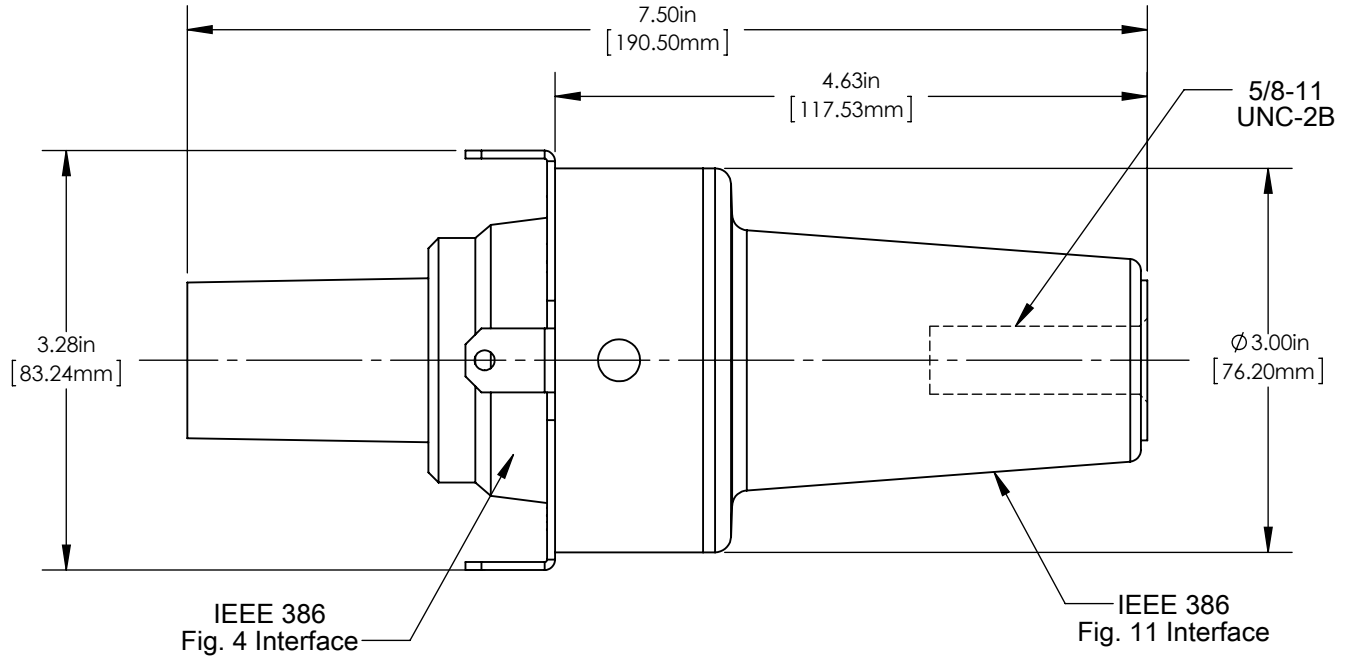

Richards 15/25 kV Reducing Tap Plug (P625RTP) converts a 600A interface (IEEE 386 Fig 11) to a 200A deadbreak interface (IEEE 386 Fig 4) for use with a 200A deadbreak elbow or cap.

The P625RTP should be assembled with a spanner wrench (P6SW) per manufacturer's instructions.

Add -LS to include loose stud (P625RTP-LS)  
Add -S to include factory installed stud (P625RTP-S)

### Product Ratings

Operating Voltage	16.2 kV L-G 28 kV L-L
Impulse Withstand	140 kV BIL
AC Withstand	45 kV
DC Withstand	84 kV
Partial Discharge	22 kV CEV

Richards 15/25 kV Reducing Tap Plug (P625RTP) was designed and validated against the following industry standards:

- ANSI/IEEE Std. 386: For Separable Insulated Connector Systems
- ANSI C119.4: For Electric Connectors
- IEEE Std. 592: For Exposed Semiconducting Shields