

15kV Bushing Extender R-800

Product Data Sheet

The Richards Bushing Extender R-800 is the only fully integrated 200A Loadbreak Tap and 600/900A Deadbreak Bushing Extender. Like many Richards Medium Voltage innovations, this product takes multiple components and combines them into a single factory molded and tested unit. This not only reduces installation cost and effort, but increases reliability and quality for our customers. The Bushing Extender R-800 is used to transition from an IEEE 386 600/900A Deadbreak interface to an IEEE 386 200A Loadbreak interface. Typical applications include:

- Installation of a 200A Loadbreak Elbow
- Installation of a 200A Surge Arrester
- Installation of an Insulating Cap, removed when testing the interface using approved voltage-indicators



Production Testing

IEEE requires a Partial Discharge test and choice between AC withstand and Impulse.

Richards runs 3/3 tests on **all** Medium Voltage products governed by IEEE 386.®

100% Routine Electrical Test:

- Partial Discharge
- AC Withstand
- Impulse Withstand

Basic Dimensions

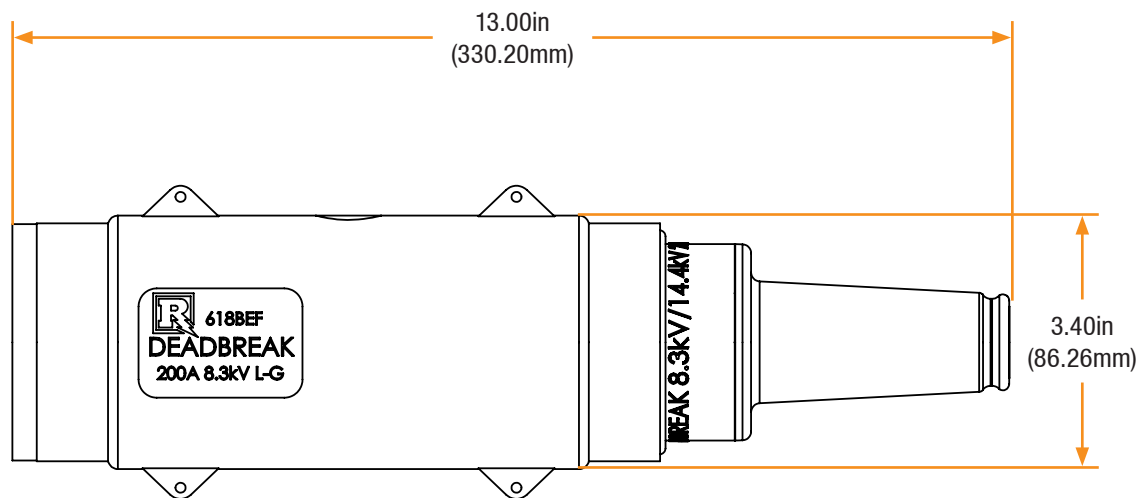

® Exceeds IEEE 386 requirement.

15kV Bushing Extender R-800

Installation

The 15kV Bushing Extender R-800 installation is covered by: **RP-II-628BE**

Related Products

618FT

15kV R-800 w/ Test Point

P625BE

15/25kV Bushing Extender

P625HIP-STUD

15/25kV Aluminum Threaded Stud

P615ETP

15kV Elbow Tap Plug

Features

- 600/900A MATING INTERFACE:** IEEE 386 Interface 11.
- THREADED STUD:** A standard threaded stud is hand-tightened into mating part before installing the Bushing Extender R-800.
- EPDM CONSTRUCTION:** Our peroxide-cured EPDM is formulated and produced completely in-house by our rubber production division. This material is durable, reliable and possesses ideal electrical properties for underground medium voltage applications.
- INTERNAL FASTENER:** To thread the Bushing Extender R-800 onto the mating interface, the installer simply rotates the internal fastener with an assembly tool (pictured) as opposed to rotating the entire EPDM housing. This makes installation as easy and simple as possible.
- SOLID INTEGRAL CONSTRUCTION:** The Bushing Extender R-800 is molded and tested as a solid, fully-integrated product. By reducing multiple components and installation steps to one, total installation cost is dramatically reduced. Further, by reducing the potential for installation errors (such as interface contamination), reliability is increased.
- SEATING INDICATOR:** The seating indicator provides visual confirmation of proper seating between the Bushing Extender R-800 and 200A Loadbreak mating part. The indicator is completely covered when seating is correct.
- 200A LOADBREAK INTERFACE:** This IEEE 386 Interface 5 (15kV) mates with a 200A Loadbreak Insulating Cap, Surge Arrester, or Loadbreak Elbow.
- DISPOSABLE INSTALLATION TOOL:** Our innovative disposable installation tool comes with every kit. The tool is zone-annealed such that the wrench yields once the required 50-60 ft-lbs of torque are achieved. No torque wrench required!

 Exceeds IEEE 386 requirement.

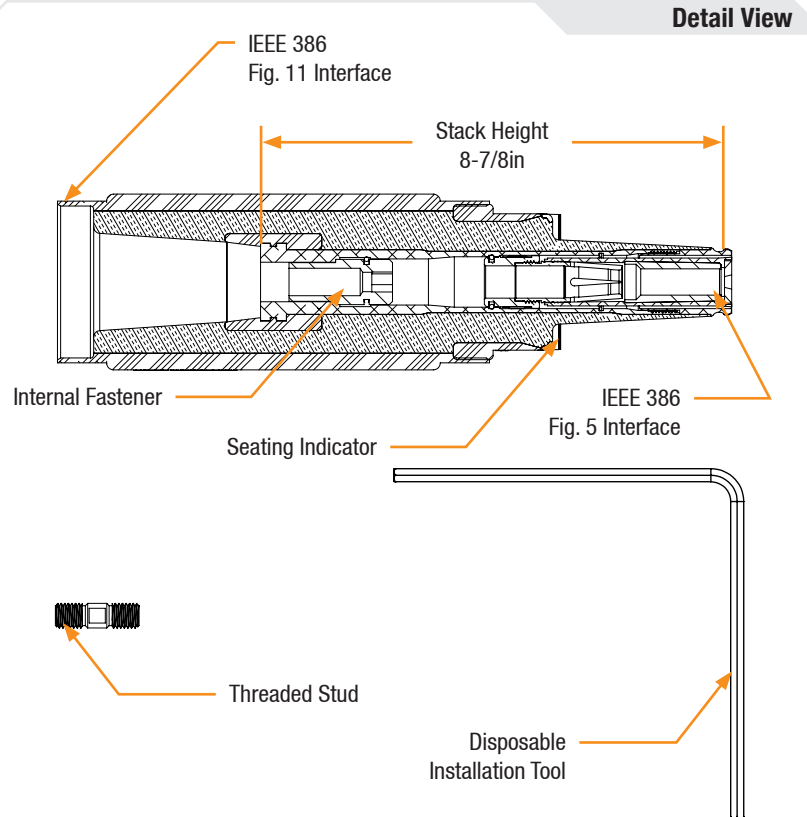

Product Ratings

Voltage Ratings	
Maximum Voltage Rating – (phase to ground)	8.3kV
Corona Voltage Level – (partial discharge extinction voltage)	11kV
AC Withstand – (1 minute)	34kV
Impulse-Withstand Voltage – (BIL)	95kV BIL

Current Ratings	
Continuous Current	200A
Short-Time Current	10kA, 10c. and 3.5kA, 3s.

The 15kV Bushing Extender R-800 is qualified to the following industry standards:

- IEEE Std 386: For Separable Insulated Connector Systems
- ANSI C119.4: For Electric Connectors
- IEEE Std 592: For Exposed Semiconducting Shields