

# 15/25/28kV Disconnectable "U" Bus

Product Data Sheet

The Richards Disconnectable Joint system is a multi-way medium voltage cable splicing system available through 35kV. Commonly found in higher load density underground systems, these Joints can be useful even for lighter loads due to their versatility and simplicity. Other methods involve complicated installations that are extremely difficult in congested underground distribution environments.

The Disconnectable Joint Bus is composed of a high-conductivity metallic bus contact overmolded with EPDM rubber. The various positions of the Bus allow for interconnection of medium voltage cables in an ultra-low-profile configuration. Accessories are also available for insulating, isolating, spiking and grounding.

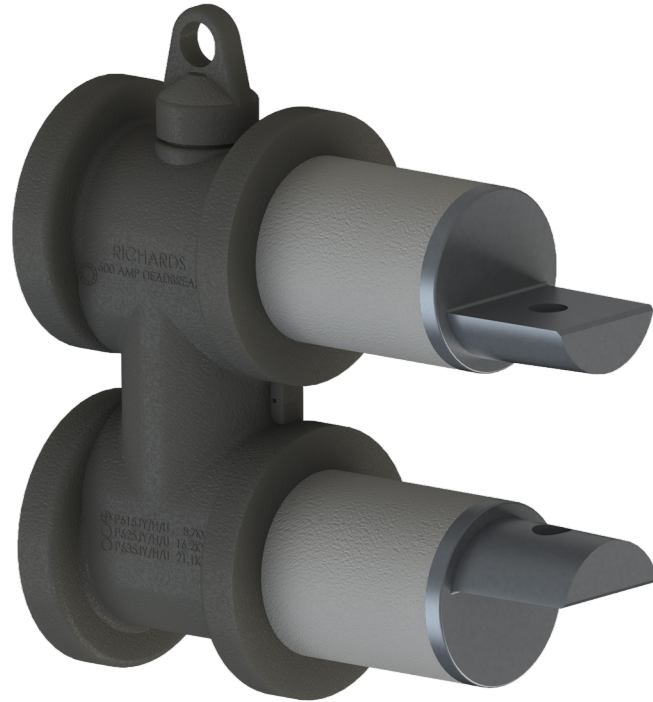

## Features

- Injection Molded & Peroxide-Cured EPDM Rubber
- Designed, Tested and Molded in the USA
- Fully-Shielded/Deadfront
- Submersible
- Dependable Multi-Way Splice
- Low-profile, space-saving splicing solution
- Modular design

## Basic Dimensions

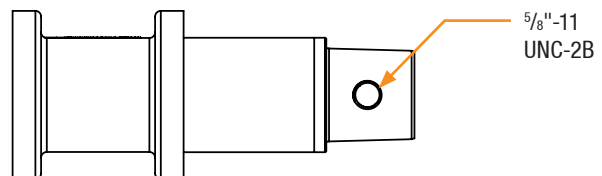
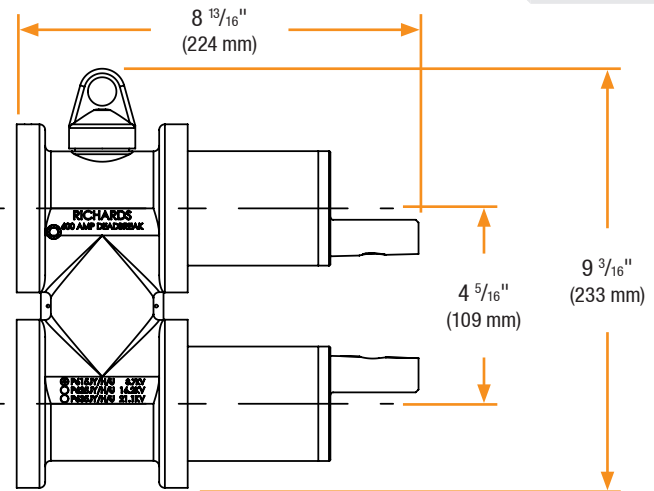

# 15/25/28kV Disconnectable "U" Bus

## Related Products

<p><b>P625JS</b> 15/25/28kV Disconnectable Joint Sleeve</p>	<p><b>P625JSCS</b> 15/25/28kV JSCS Series Cold Shrink Sleeve</p>
<p><b>92DSS0</b> 15/25/28/35kV Spiking Stem Assembly</p>	
<p><b>P625JIC</b> 15/25/28kV Joint Insulating Cap</p>	<p><b>P6JGP</b> 15/25/28kV Joint Grounding Plug</p>
<p><b>P6JPB</b> Barrier Bolt</p>	
<p><b>P6AL-X</b> Aluminum Compression Lug</p>	<p><b>P9CU-X</b> Copper Compression Lug</p>
<p><b>P6ALR-X</b> Aluminum Range Taking Lug</p>	<p><b>P7ALCU-X</b> Copper-Top Compression Lug</p>

## Detail View

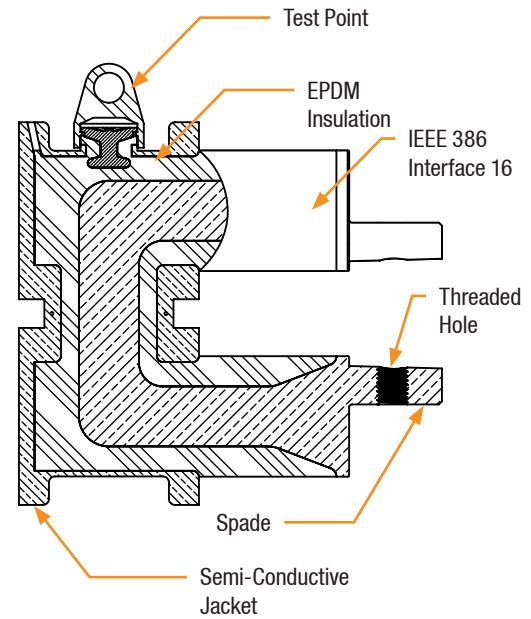

## Production Testing

IEEE requires a Partial Discharge test and choice between AC withstand and Impulse.

Richards runs 3/3 tests on **all** Medium Voltage products governed by IEEE 386. <sup>®</sup>

### 100% Routine Electrical Test:

- Partial Discharge
- AC Withstand
- Impulse Withstand

## Product Ratings

Voltage Ratings	
Maximum Voltage Rating – (phase to ground)	16.2kV
Corona Voltage Level – (partial discharge extinction voltage)	22kV <sup>®</sup>
AC Withstand – (1 minute)	45kV
Impulse-Withstand Voltage – (BIL)	162kV BIL <sup>®</sup>

Continuous Current Ratings	
Aluminum	600A
Copper	900A

Short-Time Current Ratings	
Aluminum	40kA, 10c. and 10kA, 3s. <sup>®</sup>
Copper	40kA, 10c. and 10kA, 3s.

The 15/25/28kV Disconnectable "U" Bus is qualified to the following industry standards:

- IEEE Std 386: For Separable Insulated Connector Systems
- ANSI C119.4: For Electric Connectors
- IEEE Std 592: For Exposed Semiconducting Shields
- IEEE Std 404: For Cable Joints

<sup>®</sup> Exceeds IEEE 386 requirement